

AMERICAN UNIVERSITY OF BEIRUT

**BEIRUT RAFIC HARIRI INTERNATIONAL AIRPORT:
A pleasant passenger journey**

BY

MIRA MOUNIR KHOURY

BACHELOR OF FINE ARTS (BFA) IN GRAPHIC DESIGN

DEPARTMENT OF ARCHITECTURE AND DESIGN

MAROUN SEMAAN FACULTY OF ENGINEERING AND ARCHITECTURE (MSFEA)

BEIRUT, MAY 26, 2020

AMERICAN UNIVERSITY OF BEIRUT

UNDERGRADUATE SENIOR PROJECT
IN
GRAPHIC DESIGN

SUBMITTAL FORM

BEIRUT RAFIC HARIRI INTERNATIONAL AIRPORT:
A PLEASANT PASSENGER JOURNEY
by
MIRA MOUNIR KHOURY

GD 407 – FINAL YEAR THESIS PROJECT
SPRING 2019-2020

ADVISOR: MIA AZAR

--

Approved by Thesis Advisor:



Mia Azar, Lecturer
Department of Architecture and Design
Maroun Semaan Faculty of Architecture and Design

Date of Thesis final presentation: May 14, 2020

AMERICAN UNIVERSITY OF BEIRUT
THESIS, DISSERTATION, PROJECT RELEASE FORM

Student Name: **KHOURY MIRA MOUNIR**

- ArDT Project (Architecture Design Thesis)
 GDRP Project (Graphic Design Research Project)

I authorize the American University of Beirut to: (a) reproduce hard or electronic copies of my project; (b) include such copies in the archives and digital repositories of the University; and (c) make freely available such copies to third parties for research or educational purposes.

I authorize the American University of Beirut, to: (a) reproduce hard or electronic copies of my project; (b) include such copies in the archives and digital repositories of the University; and (c) make freely available such copies to third parties for research or educational purposes

after : **One year from the date of submission of my capstone project.**
 Two years from the date of submission of my capstone project.
 Three years from the date of submission of my capstone project.



Signature

26/05/2020

Date

This form is signed when submitting the thesis, dissertation, or project to the University Libraries.

ACKNOWLEDGMENTS

The completion of this project could not have been possible without the help, support and assistance of so many people whose name may not all be enumerated. Their contributions are sincerely appreciated and gratefully acknowledged. I would like to express my special appreciation and thanks particularly to the following:

My advisor, **Ms. Mia Azar** for imparting her knowledge and expertise in the project and for guiding me through.

The Beirut Rafic Hariri International Airport Security Authority and Presidency, for giving me the possibility to access the Airport and completing my project. And especially, **Colonel Ahmad Baytamouni** for giving me his huge help and support since the beginning in completing my project successfully.

Most importantly, I would like to thank my **family** and **friends** for supporting me morally and for their encouragement and motivation towards the completion of this project.

ABSTRACT

My Final Year Project consists of creating a **new, pleasant, and user friendly passenger experience** for the **Beirut Rafic Hariri International Airport** through a **signage and environmental graphics system**.

Before starting, many critical questions need to be raised in order to achieve a successful project. **Is wayfinding fundamental to the function of an airport? Does it contribute to the traveler's experience and add to the value of the environment? How can graphic design complement an architectural space? Do the environmental graphics contribute in creating an effective wayfinding?**

The Beirut Rafic Hariri International Airport is currently being renovated and needless to say that it doesn't have the most exciting wayfinding system. I saw it as a good opportunity to create a new signage system and modernize its graphic environment. In my opinion, the **airport** has to be **memorable as a space**, and **signage** is a **powerful visual tool for communication** and a crucial component of visual identity.

TABLE OF CONTENTS

- I- Signage Manual: book documentation
- II- Signage Manual: full electronic copy

I- Signage Manual: book documentation



BEIRUT RAFIC HARIRI
INTERNATIONAL AIRPORT:
A pleasant passenger journey

*Signage and Environmental
Graphics Manual*
Designed by Mira Khoury

BEIRUT RAFIG HARIRI
INTERNATIONAL AIRPORT:
A pleasant passenger journey

Environmental

- I- Introduction of the project P-3
- II- Extensive field work and space study P-5
 - 1- Airport circulations P-6
 - 2- Audliencing P-10
- III- Design concept P-15
- IV- Design elements and specifications P-19
 - 1- Typeface P-20
 - 2- Trilingual application P-22
 - 3- Airport color scheme P-24
 - 4- Color coding and color palette P-26
 - 5- Pictograms P-34
 - 6- Arrows P-54
 - 7- Sign plate grids and modulations P-58
- V- Signage and environmental design implementations P-65
 - 1- Sign type, shape and function P-66
 - 2- Family shot P-70
 - 3- Directional signage P-73
 - 4- Identification signage P-105
 - 5- Informational signage P-129
 - 6- Regulatory signage P-147
 - 7- Covid-19 customized [furniture] P-161
 - 8- Family shot P-167
- VI- User scenarios P-173
 - 1- Current state scenario [departure] P-175
 - 2- Proposed design scenario [departure] P-179
- VII- Annex P-197
 - 1- Site visits P-198
 - 2- Acknowledgements P-203



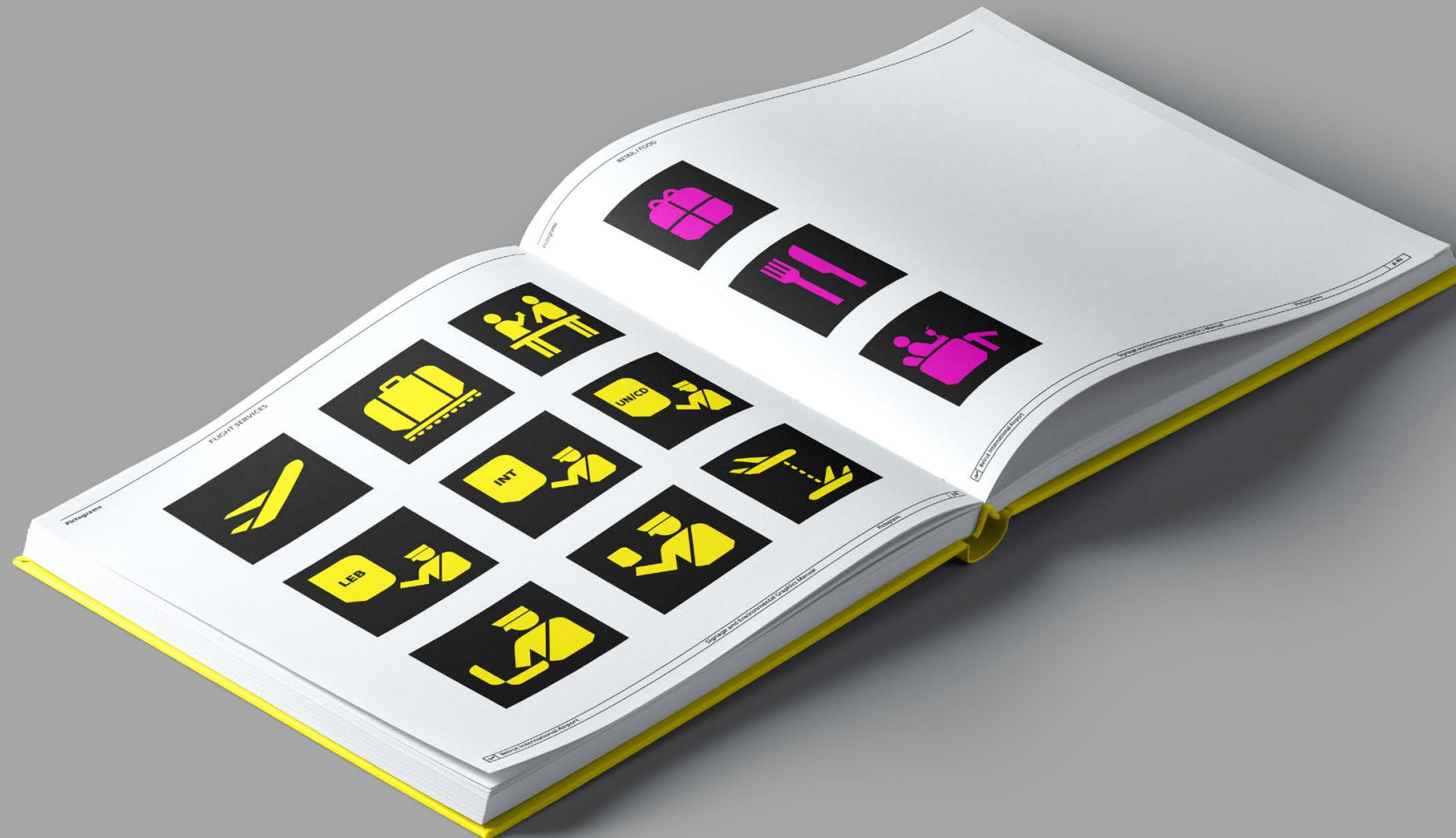

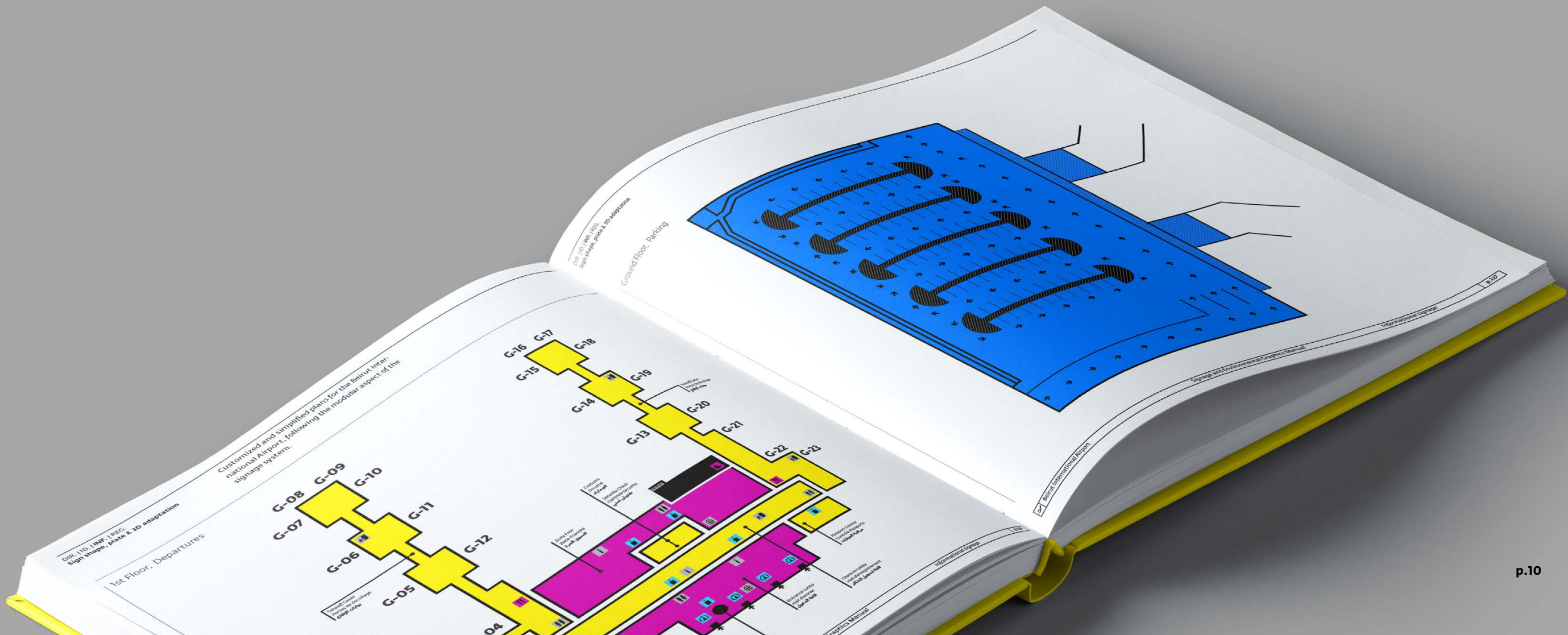

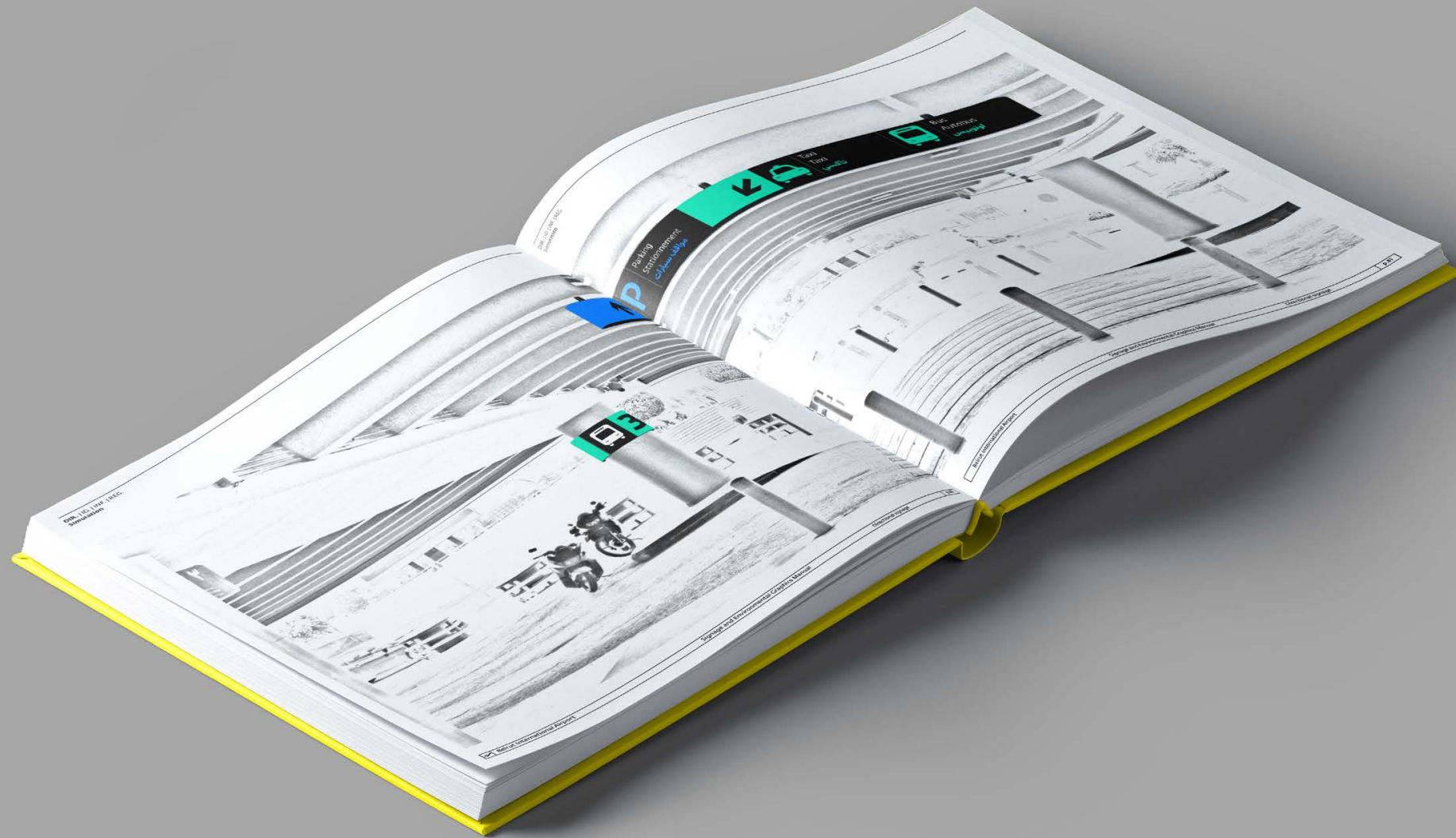



Arrows

Beirut Rafic Hariri International Airport

Signage and Environmental Graphics Manual

Arrows

Signage and Environmental Graphics Manual

Beirut Rafic Hariri International Airport

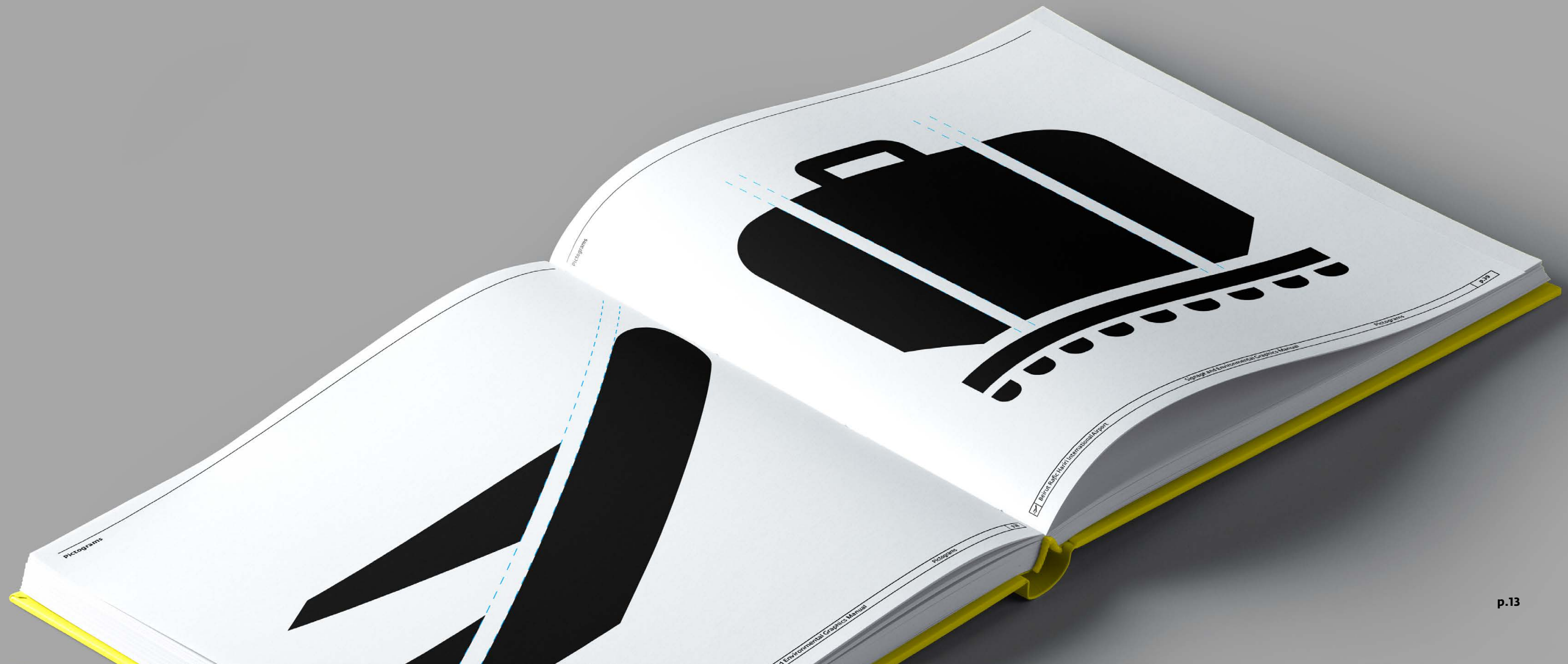

Circle is found almost everywhere in the airport and especially in walkways.

Customizable modules leading to different heights/lengths.
Based on one module 35x35cm.

DIR-Squirrel Wireframe front view

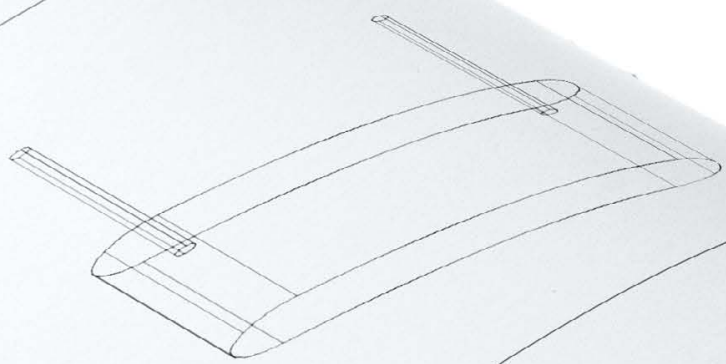

DIR-Squirrel 3D side/bottom view

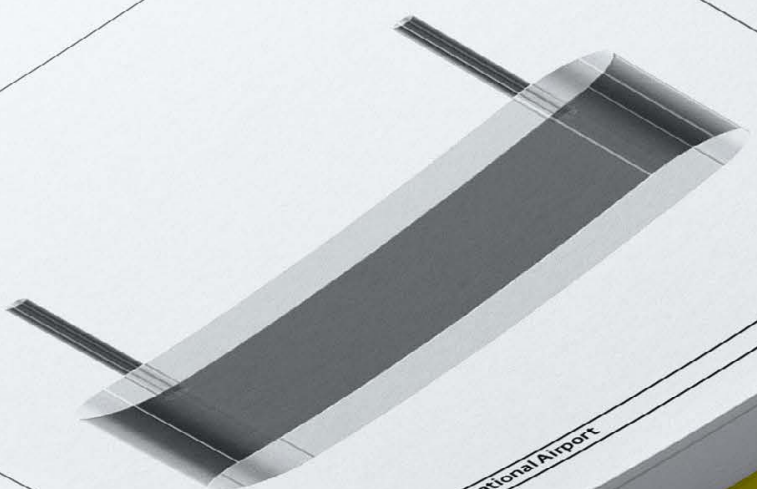

DIR-Squirrel 3D front/bottom view

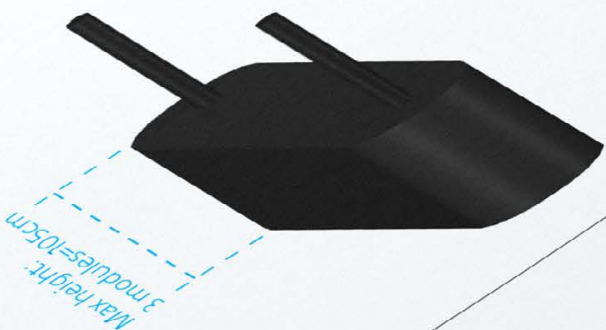

Max height 3 modules=105cm

DIR-110-11NF-18CC Sign shape plate & 3D adaptation

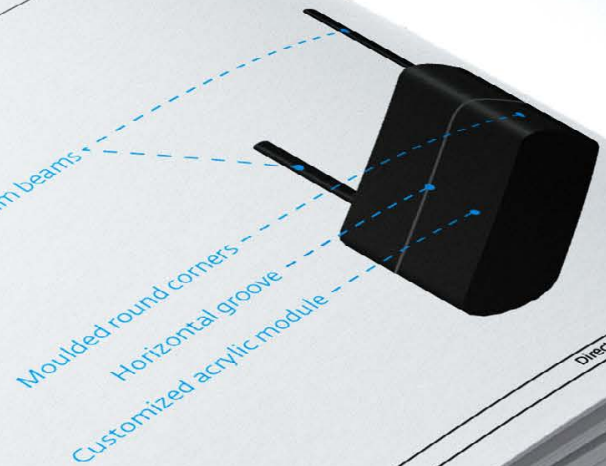

Cylindrical aluminum beams

Moulded round corners

Horizontal groove

Customized acrylic module

I- Signage Manual: full electronic copy

BEIRUT RAFIC HARIRI
INTERNATIONAL AIRPORT:
A pleasant passenger journey



Signage and Environmental
Graphics Manual

Designed by Mira Khoury

**BEIRUT
INTERNATIONAL AIRPORT:
A pleasant passenger journey**



Graphics Manual
Signage and Environmental

Contents

I-	Introduction of the project	p.3
II-	Extensive field work and space study	p.5
	1- Airport circulations	p.6
	2- Audiencing	p.10
III-	Design concept	p.15
IV-	Design elements and specifications	p.19
	1- Typeface	p.20
	2- Trilingual application	p.22
	3- Airport color scheme	p.24
	4- Color coding and color palette	p.26
	5- Pictograms	p.34
	6- Arrows	p.54
	7- Sign plate grids and modulations	p.58
V-	Signage and environmental design implementations	p.65
	1- Sign type, shape and function	p.66
	2- Family shot	p.70
	3- Directional signage	p.73
	4- Identification signage	p.105
	5- Informational signage	p.129
	6- Regulatory signage	p.147
	7- Covid-19 customized furniture	p.161
	8- Family shot	p.167
VI-	User scenarios	p.173
	1- Current state scenario [departure]	p.175
	2- Proposed design scenario [departure]	p.179
VII-	Annex	p.197
	1- Site visits	p.198
	2- Acknowledgements	p.203

Introduction of the project

My FYP project consists of creating a new, **pleasant**, and **user friendly passenger experience** for the **Beirut Rafic Hariri International Airport** through a **signage and environmental graphics system**.

Before starting, many critical questions need to be raised in order to achieve a successful project.

Is **wayfinding** fundamental to the **function of an airport**?

Does it contribute to the **traveler's experience** and add to the **value of the environment**?

How can **graphic design complement an architectural space**?

Do the **environmental graphics** contribute in creating an **effective** wayfinding?

"The airport is not just an international territory, it's also an **entrance to a territory**, so the aesthetics of the signage has to connect with the aesthetics of the country." - Ruedi Baur.

The Beirut Rafic Hariri International Airport is currently being renovated and needless to say that it doesn't have the most exciting wayfinding system. I saw it as a good opportunity to create a new signage system and **modernize** its graphic environment.

In my opinion, the airport has to be **memorable as a space**, and signage is a **powerful visual tool** for communication and a crucial component of visual identity.

Airports are vast and complex environments that absolutely need an **effective, clear and consistent wayfinding system**. A system that needs to assure that the areas within the airport are carefully organized and planned in order for the travelers to arrive to their gate in the **fastest and easiest way** possible.

«Finding the way in airports is primary transfer-related from ground transport to air transport, from air transport to ground transport and from air transport to air transport.» - Per Mollerup.

Airport signage is impacted by many International

standards, regulations and guidelines. Nonetheless, this project requires an equal hierarchy of trilingual typography since it is an international airport.

To plan wayfinding in a large building, a **site planning** is essential. Indeed, after going through the airport several times, studying and inspecting it closely and thoroughly, I was able to identify all the existing signs, analyze and understand the function and type of every one of them. Through this process, I was able to understand that the travelers need to find the proper signage and information in the most predictable space and at the right time. It is like a problem-solving process that should include all the steps needed to **move from point A to point B**.

Creating a great wayfinding experience is not just about the signage placement, legibility, contrast, colors... but it is essentially **how the architecture and the signs work together harmoniously** in the whole environment. Often, wayfinding is lost in the character of the architectural environment, and this is where I find it the most interesting. Indeed, there isn't a particular approach for creating a signage system, every environment has an appropriate and suitable solution.

As Tom Esch, signage manager for the Norman Y. Mineta San Jose International Airport said "**Every airport has a unique architecture and conditions that dictate the final signage and wayfinding solutions.**"

Beyond wayfinding, **environmental graphics** can serve as a **major contributor** to create an **engaging journey** and experience for the travelers. It also gives them a **sense of place and reference**, helping them locate themselves within the airport (departure/arrival).

II- EXTENSIVE FIELD WORK AND SPACE STUDY

Airport Circulations | Departure

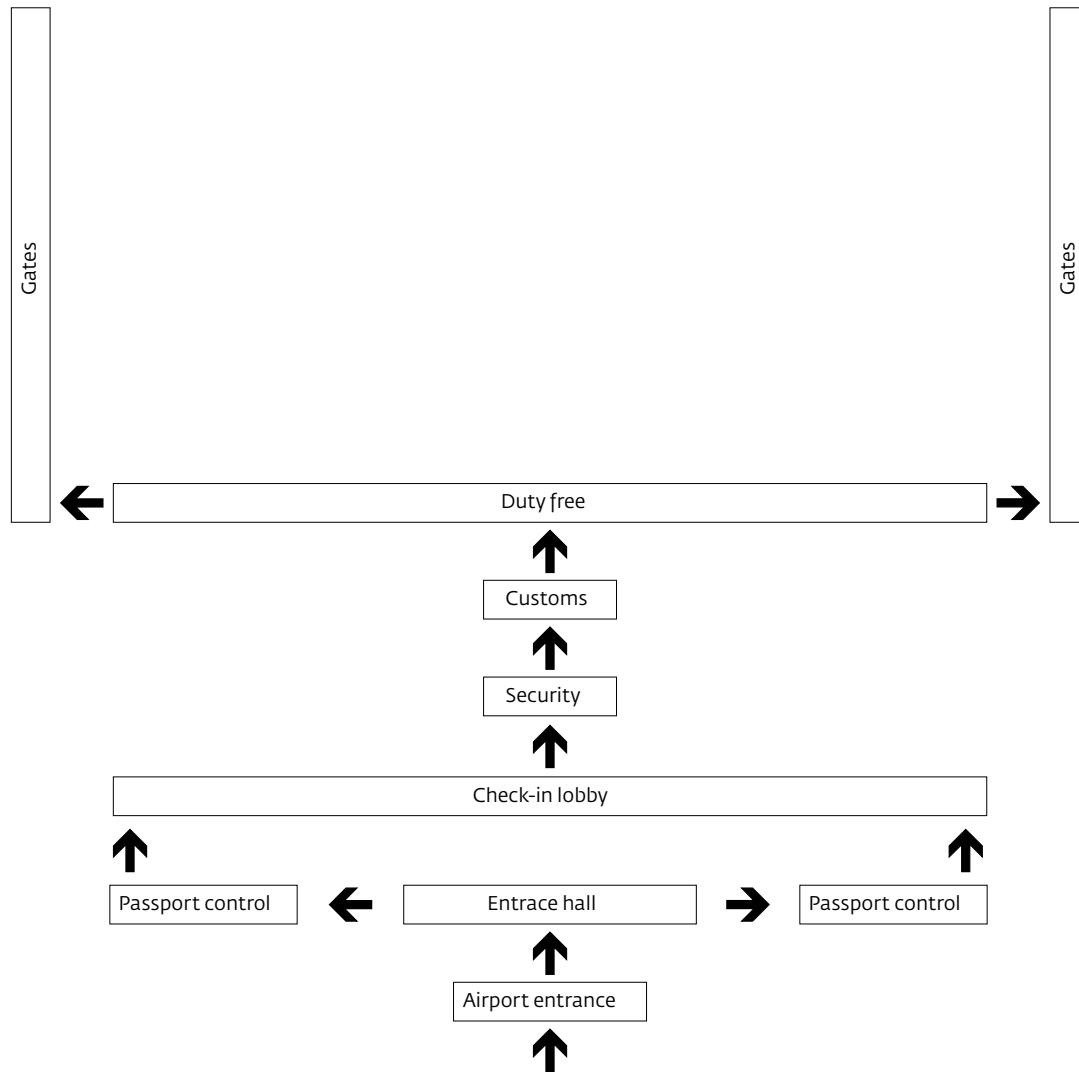

Airport Circulations | Arrival

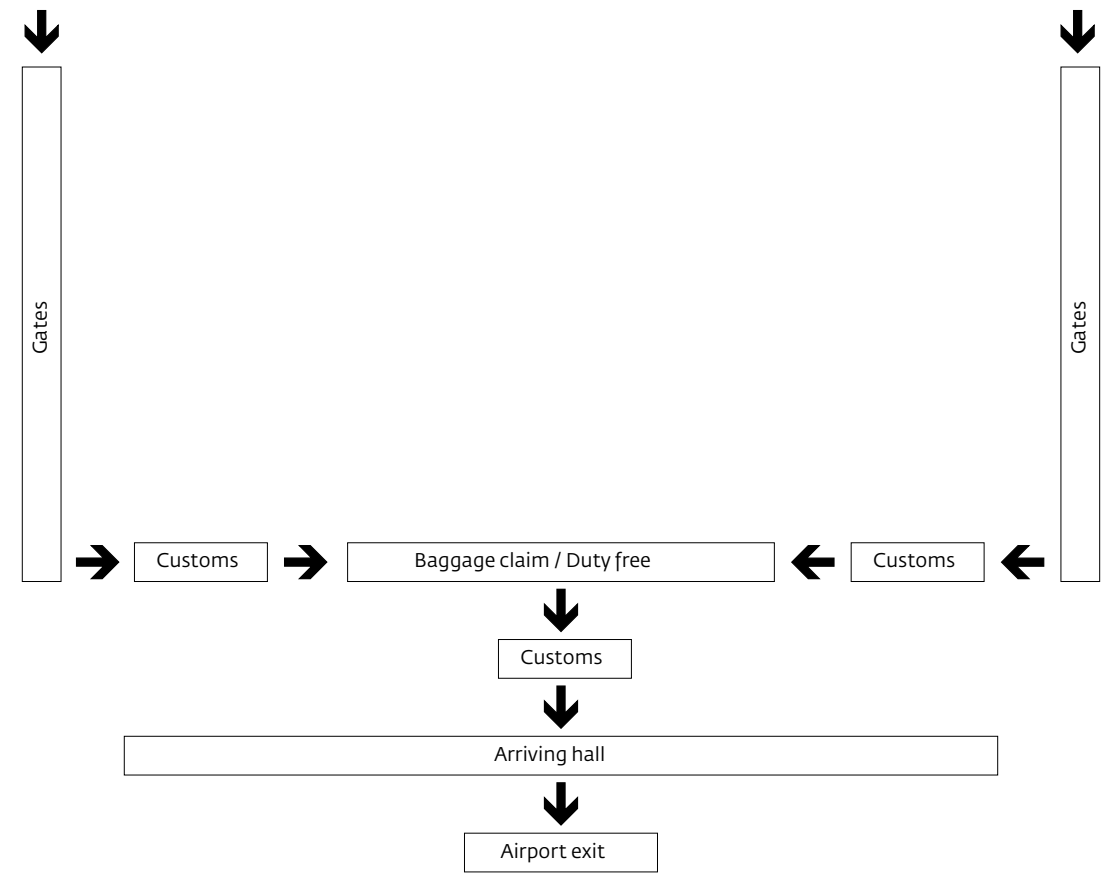

Airport Circulations

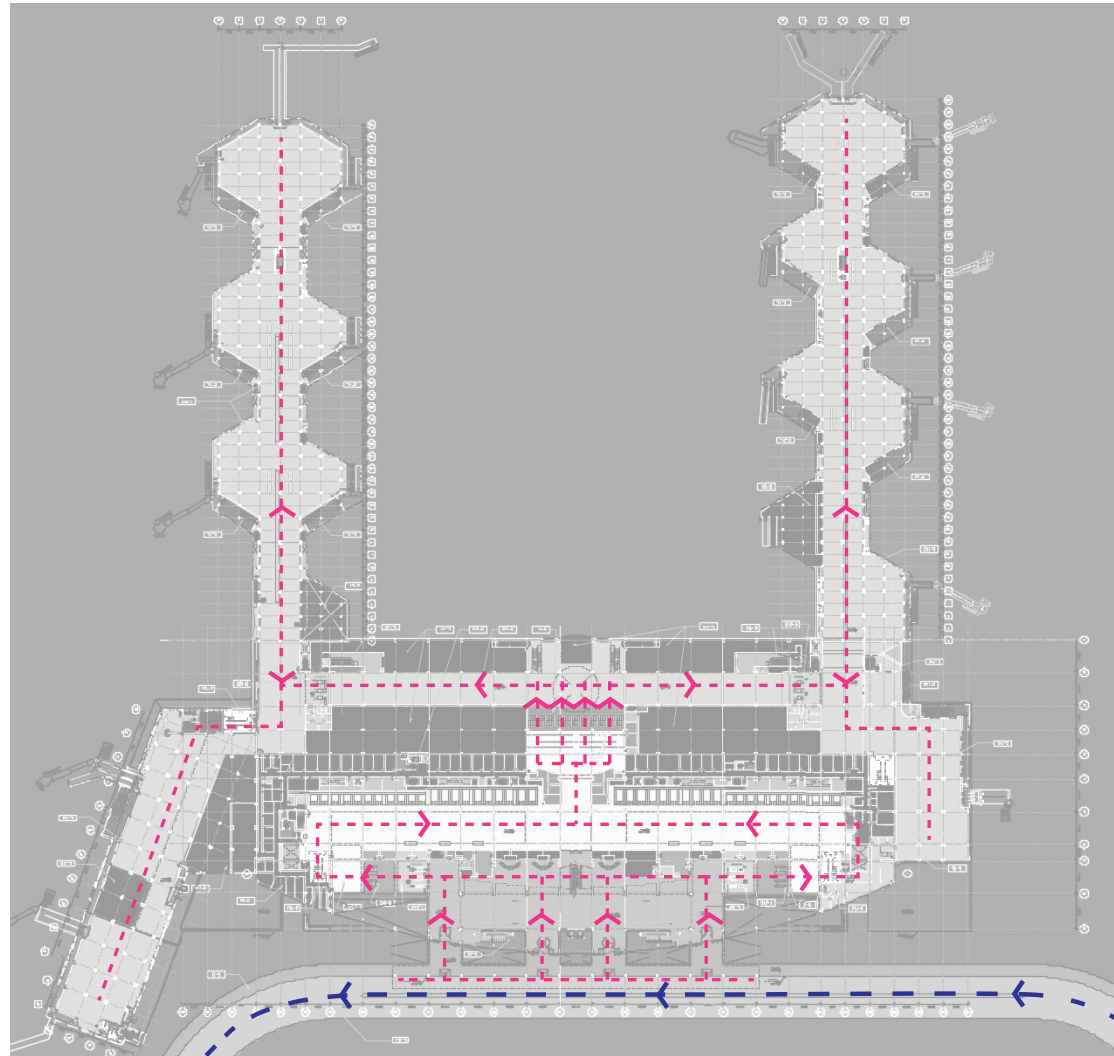

- - - Pedestrians
- - - Vehicles

Airport Circulations

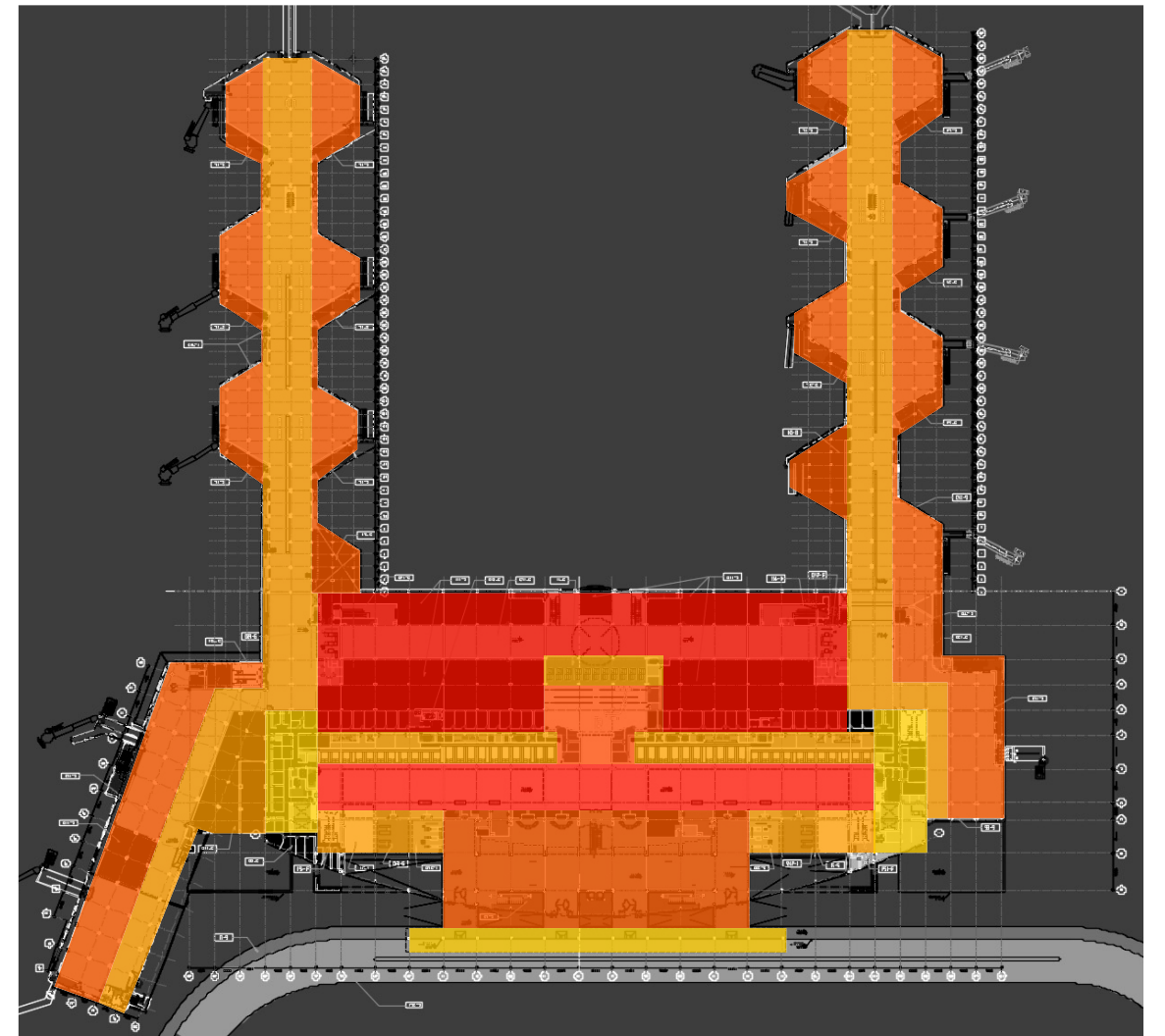

- 0 100
- Private lounges
 - Other areas/transitional
 - Restaurants, Cafe-matik, Gates
 - Security
 - Duty-free, Check-in area

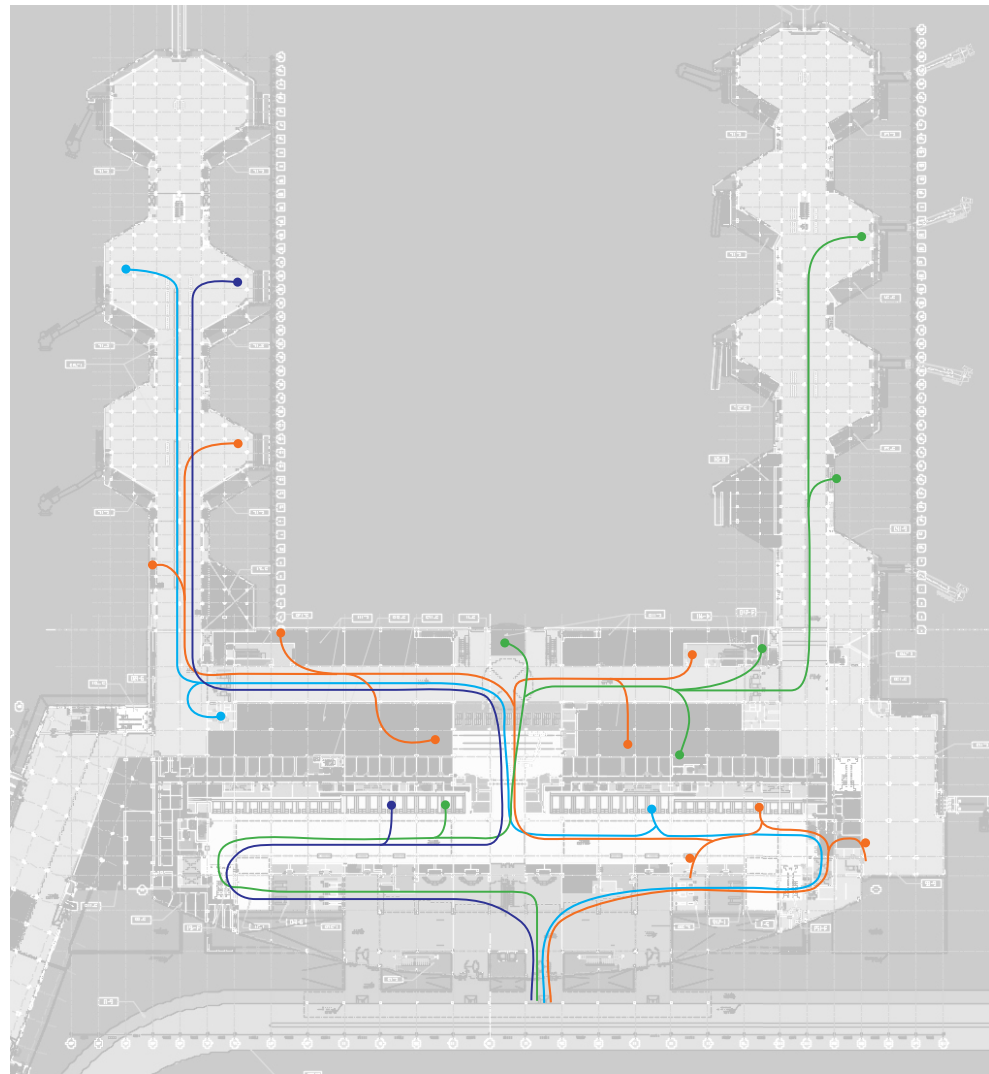

USER FLOW

- Business People
- Families
- Students
- Seniors

PSYCHOGRAPHICS (Attitudes, Mindset, Behaviour)

Business People	Families	Students	Seniors
-Impatient	-Kids/babies	-Stress	-Vision problems
-Anxious	-Arrive on time	-Under 18 accompanied	-Anxious
-Dont want to miss flight	-Not lose one another	-Alone	-Need facilities
-Added fatigue	-Added fatigue	-Added fatigue	-Old people accompanied
			-Added fatigue

Audiencing

Terminal users include familiar and unfamiliar passengers and visitors. The wayfinding system must consider and accomodate all terminal visitors and passengers.

Travelers	Seniors Families Students Business people Disabled people
Employees	Engineers Officers Secretary Janitors Helpers Workers
Aircrew	Captain Pilot Co-pilot Flight attendant
Welcoming People	Seniors Families Students Business Men Disabled people

- - - - - Travelers
- - - - - Employees
- - - - - Aircrew
- - - - - Welcoming People

Audiencing

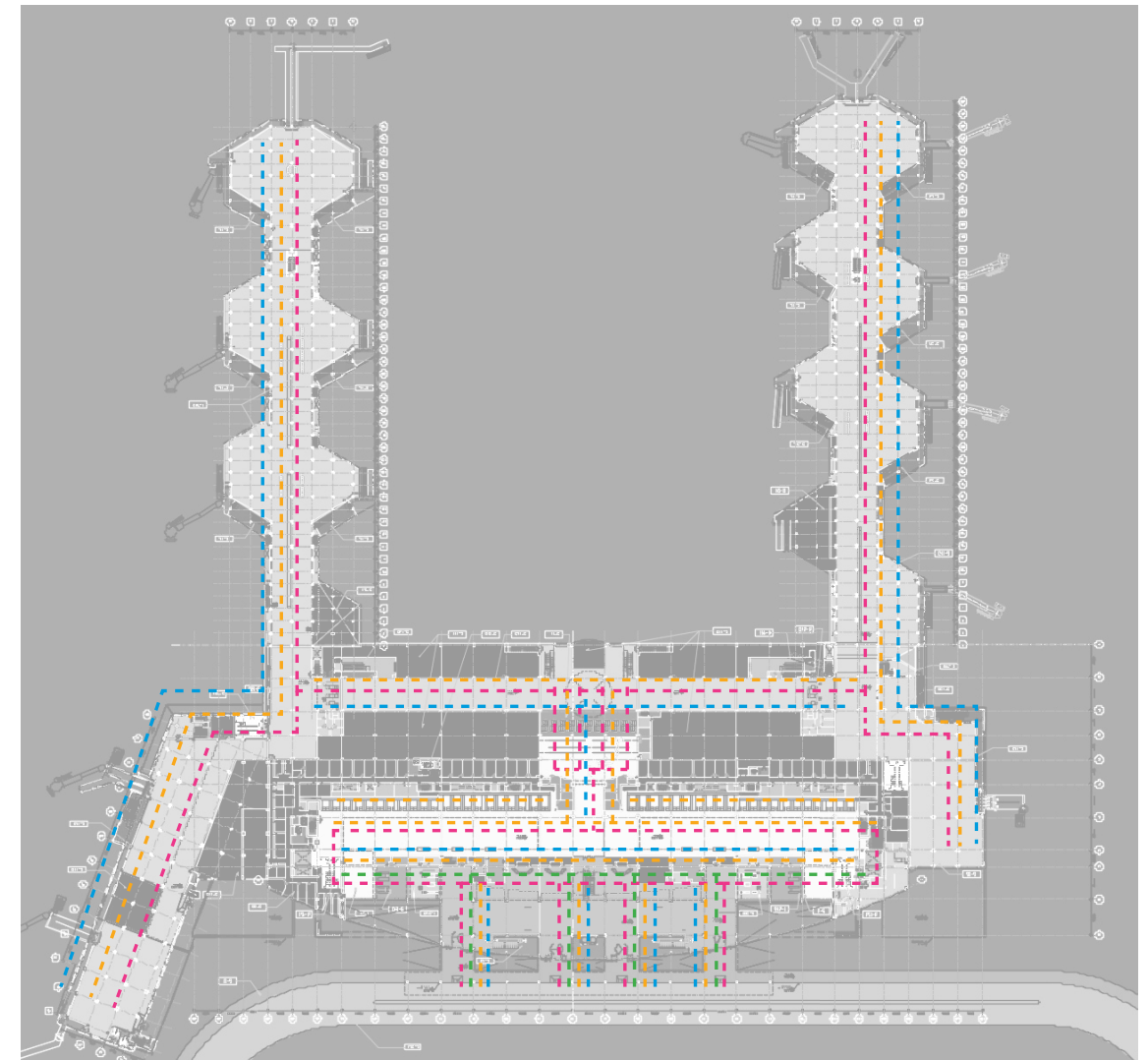

Design Concept

The main purpose of this project is to create a **harmonious and pleasant passenger experience** by having the signage lost in the character of the architectural environment. My objective is to **unify Architecture and Graphic Design** by representing them as **one entity**.

After an extensive field work, I noticed the **excessive number of poles** found almost everywhere in the Airport. Being inspired by the space, I decided to **make use of the existing structural elements** and **complement** them with the **signs** and the **environmental graphics** I'm creating. The main architecture element, the pole, was a source of inspiration for my project.

Emphasizing on the cylindrical aspect of the poles, I designed my signs based on circularity, providing a **360 degrees visibility** for the travelers.

As I was looking at the structural poles extending to the ceiling, I imagined their virtual ascension, joining together ground and sky, which constitute the purpose of the take-off. Thus, **I wanted to enhance the cylindrical shape** representing it as a **tunnel to the sky, linking the outside in**. Having **2 huge cylinders** in the airport (main entrance and center of duty free), serving as **masterpieces**, provide **2 reference keypoints** for the passengers in their travel experience.

In order to create a memorable and pleasant passenger experience, I needed to put myself in the shoes of the traveler and **follow** his/her exact **path**, from the entrance, to the plane, taking into consideration every step, **what is he/she going to see, when and how**.

Through the **different visits to the airport**, for both travel and the purpose of the project, I noticed that there are **no windows** (except in the

main entrance and VIP lounges). The **lighting is very bad** as well, and the **environment is very dull; gray white and black**. This made me feel I'm in a very closed space, without anything making me **connect to the outside**.

That's what led me to the idea of **bringing the outside in**, having some moments of calm and tranquility whether through **digital moving images of the outside (sky, clouds...)**, bright colors or big photographs of **landscapes**, serving as advertisements for LiveLoveBeirut.

Moreover, it is very important for the **signs to be read and understood quickly**. Indeed, I created a **clear and visible modular system** having as a reference the **square module**, which became a main **design element** used across the project.

Apart from that, after the spread of **COVID-19** and after everything that's been happening in the world so far, I wanted to include this **new way of life** in my project. Rightly so, people have become obsessed with **hygiene**, and I thought this aspect would add **authenticity** and **actuality** to my project.

Nonetheless, the airport is a public space that is now **threatened by the virus** and people **don't feel safe travelling**, so I created a **sterilizing tunnel** that people would pass by in order to sanitize. This tunnel is found at the entrance of the airport. Along with a **sanitizing passport device** which is fixed on a pole, available after every **interaction with an individual** (check-in, passport control, customs) in order to sanitize the traveler's passport.

COMPLEMENTING THE ARCHITECTURAL SPACE

BRINGING THE OUTSIDE IN

PLEASANT, ENGAGING INTERACTIVE EXPERIENCE

UNIFY ARCHITECTURE AND GRAPHIC DESIGN

TUNNEL FROM THE SKY

MEMORABLE SPACE

FUNCTIONALITY

FLEXIBILITY

PLACE-MAKING

MODERNIZING

CLARITY AND SIMPLICITY

SENSE OF REFERENCE

IV- DESIGN ELEMENTS AND SPECIFICATIONS

**ABCDEFGHIJKLM-
NOPQRSTUVWXYZ**

**abcdefghijklm-
nopqrstuvwxyz**

1234567890 - . , []

**أ ب ت ث ج ح خ د ذ ر ز
س ش ص ض ط ظ ع غ
ف ق ك ل م ن ه و ي ي**

١٢٣٤٥٦٧٨٩٠

Trilingual application

Bold weight of Fedra Sans Arabic used to highlight the Arabic message since it's the Beirut airport. Book weight of Fedra Sans Latin, since it's been found to have the easiest legibility. Being an in-

ternational airport, the English was chosen to be on top. And being an official language in Lebanon, the French was chosen to be second. Having the Arabic at the bottom to create a balance and

English 188 pt

French 270 pt 188 pt

العربية 270 pt 188 pt

Left aligned

Trilingual application

contrast in the hierarchy while still making it stand out in bold.

English

العربية

Airport color scheme

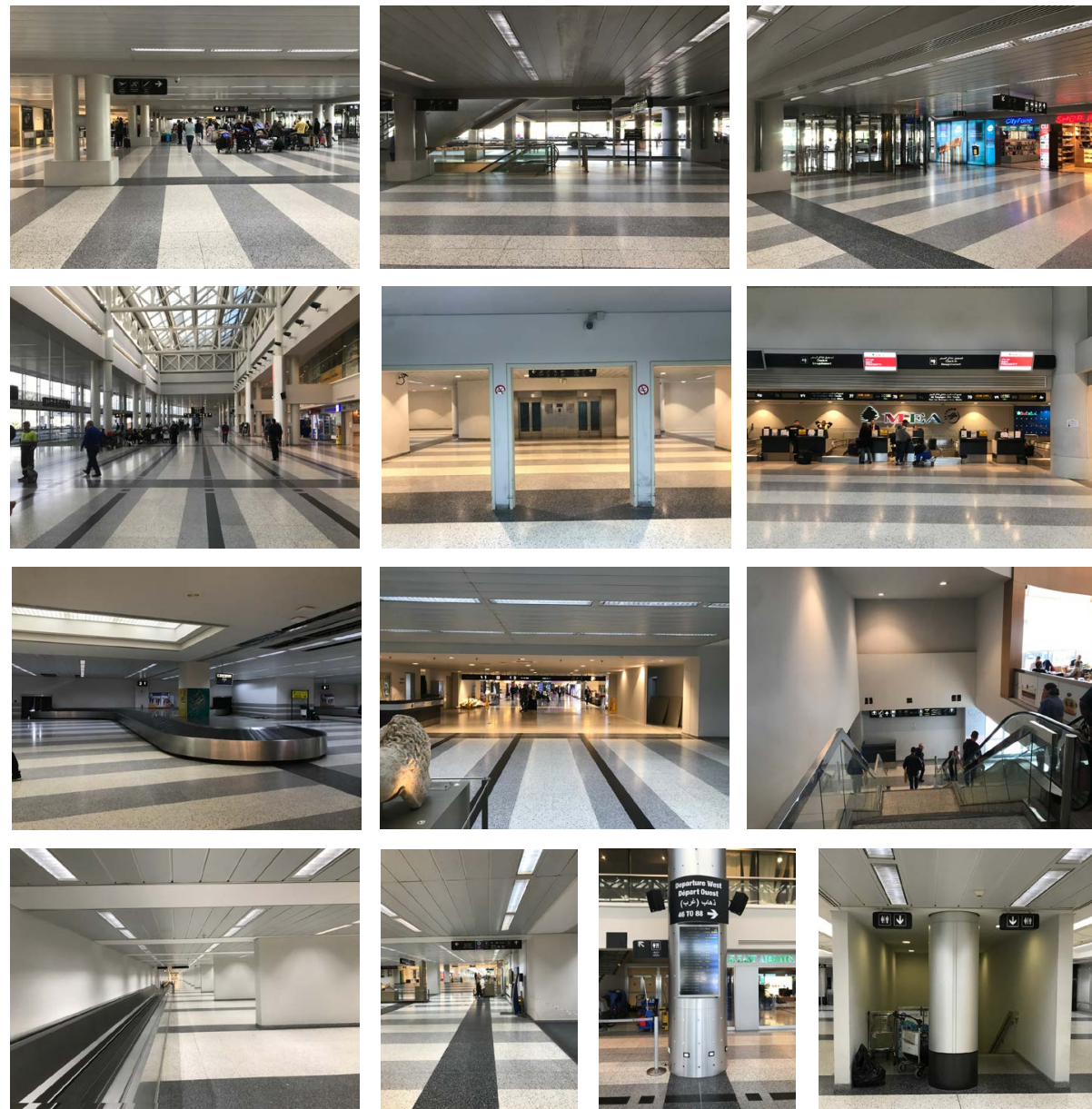

Airport color scheme

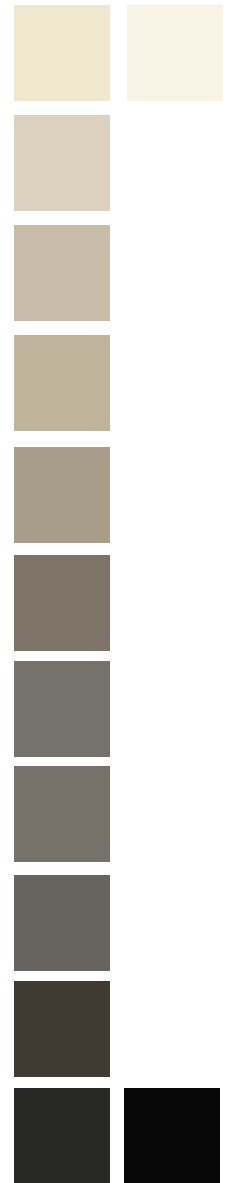
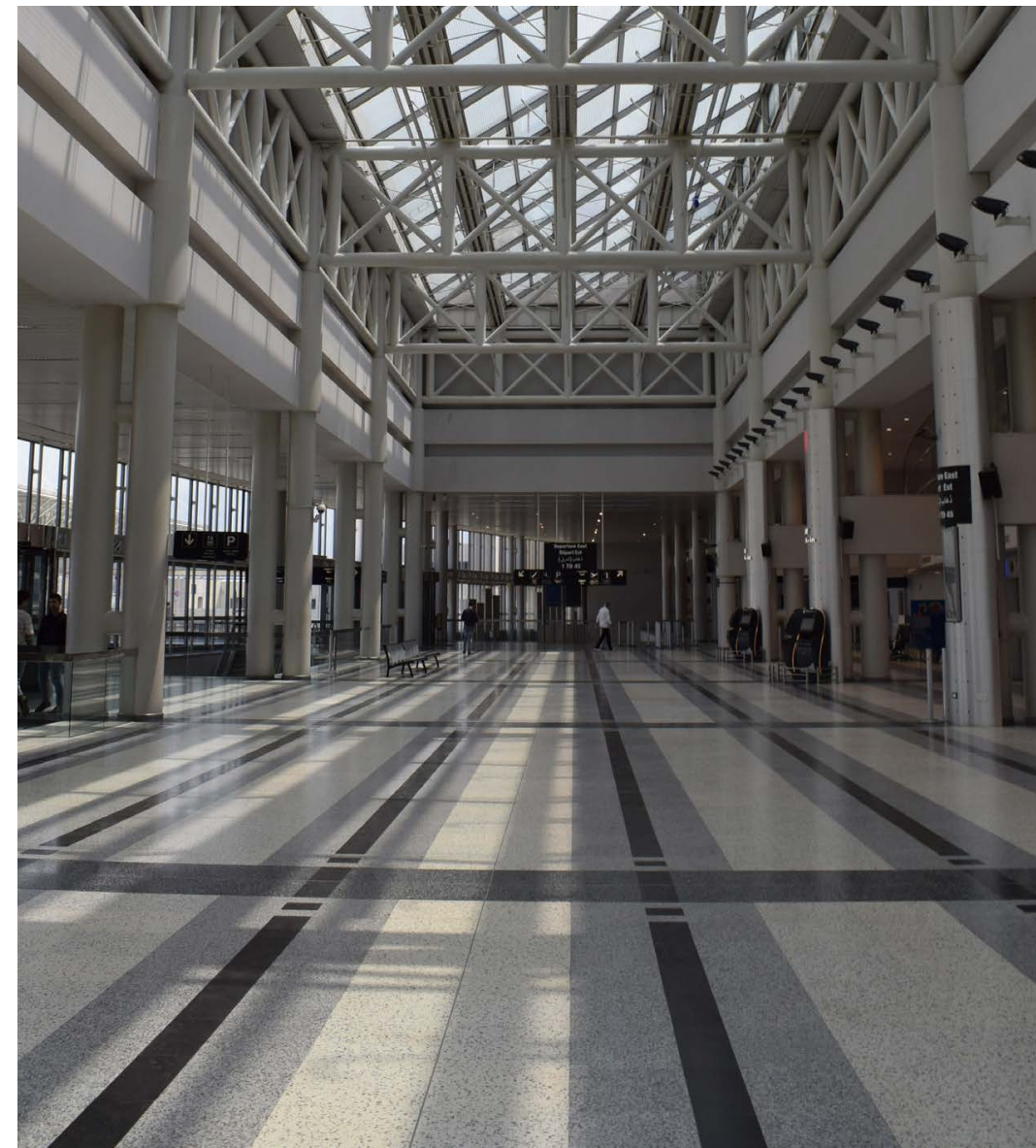

FLIGHT INFORMATION

DEPARTURES

ARRIVALS

GATES

CHECK-IN

PASSPORT CONTROL

CUSTOMS

#fce805
R:252 , G:232 , B:5
C:4 , M:2, Y:99, K:0

RETAIL / FOOD

DUTY FREE

RESTAURANTS

LOUNGES

#d900ab
R:217 , G:0 , B:171
C:20 , M:92, Y:0, K:0

**GROUND
TRANSPORTATION**
PUBLIC TRANSPORT
CAR RENTALS

#00d5aa
R:0 , G:213 , B:170
C:66 , M:0, Y:48, K:0

PARKING

#007aff
R:0 , G:122 , B:255
C:78 , M:53, Y:0, K:0

AIRPORT SERVICES

TOILETS

INFORMATION

ATM

ELEVATORS

#b0b5b5
R:176 , G:181 , B:181
C:32 , M:23 , Y:24 , K:0

COVID-19, HYGIENE RELATED INFO.

SANITIZING TUNNELS

SANITIZING DEVICES

PRECAUTIONS INFO.

#2bcff6
R:43 , G:207 , B:246
C:61 , M:0 , Y:3 , K:0

REGULATORY
NO SMOKING
DO NOT ENTER
PERSONEL ONLY

#2bcff6
R:43 , G:207 , B:246
C:61 , M:0, Y:3, K:0

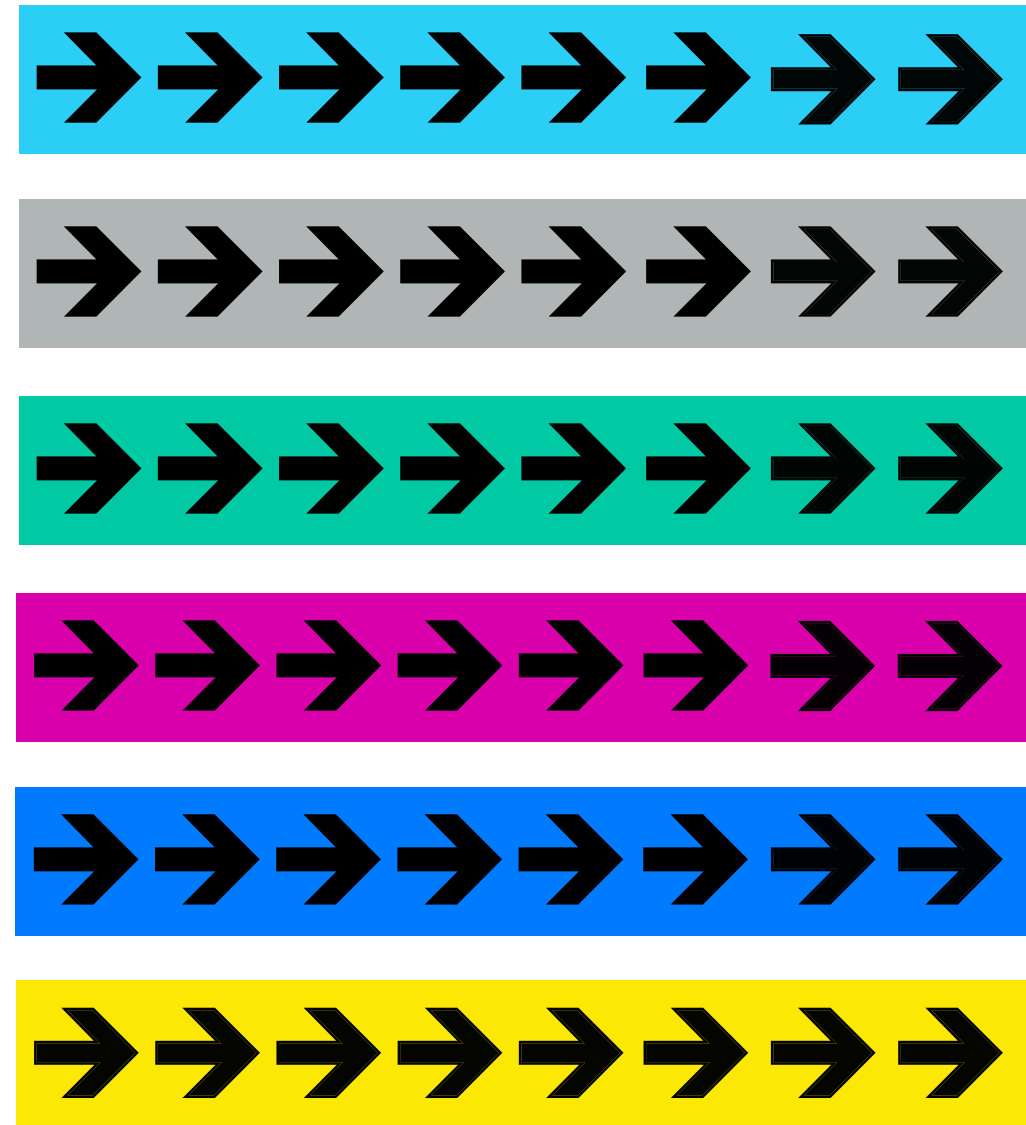

Pictograms

Series of customized pictograms created for the Beirut International Airport as an extension of the typography.

They are drawn to match the details of Fedra Sans.

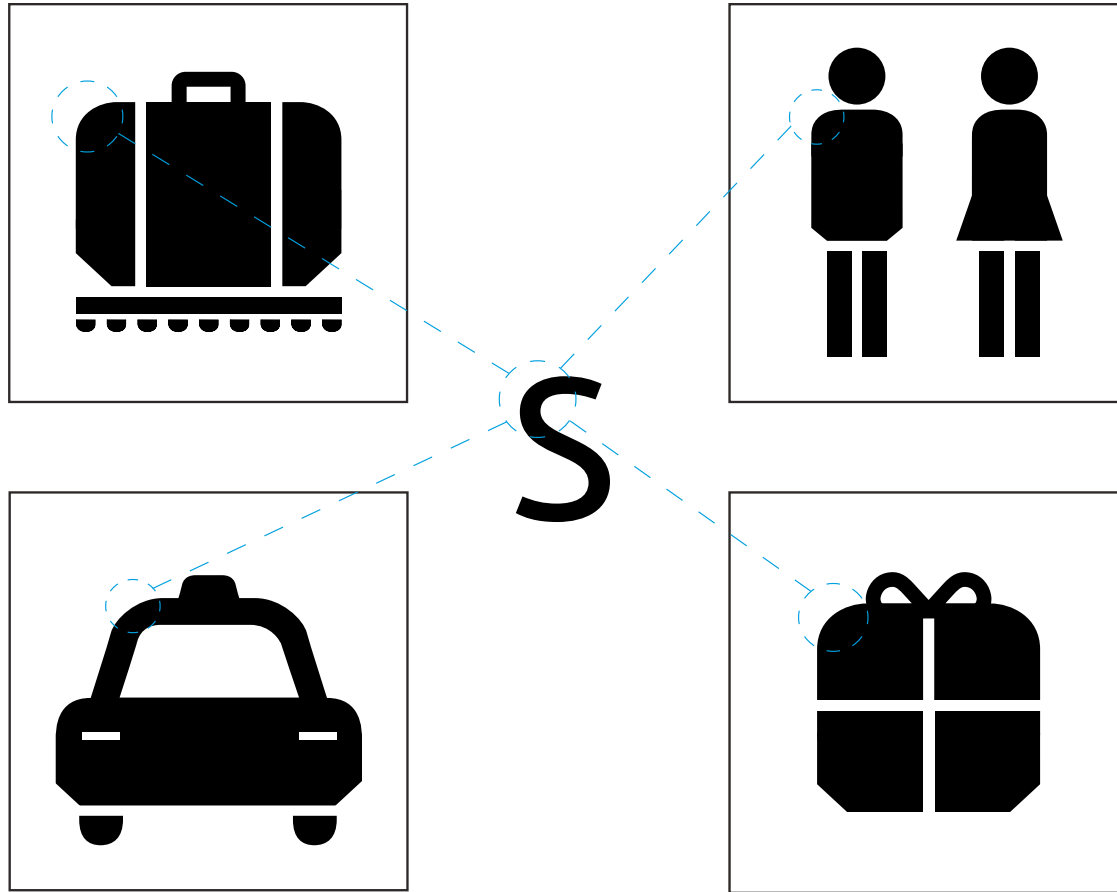

Pictograms

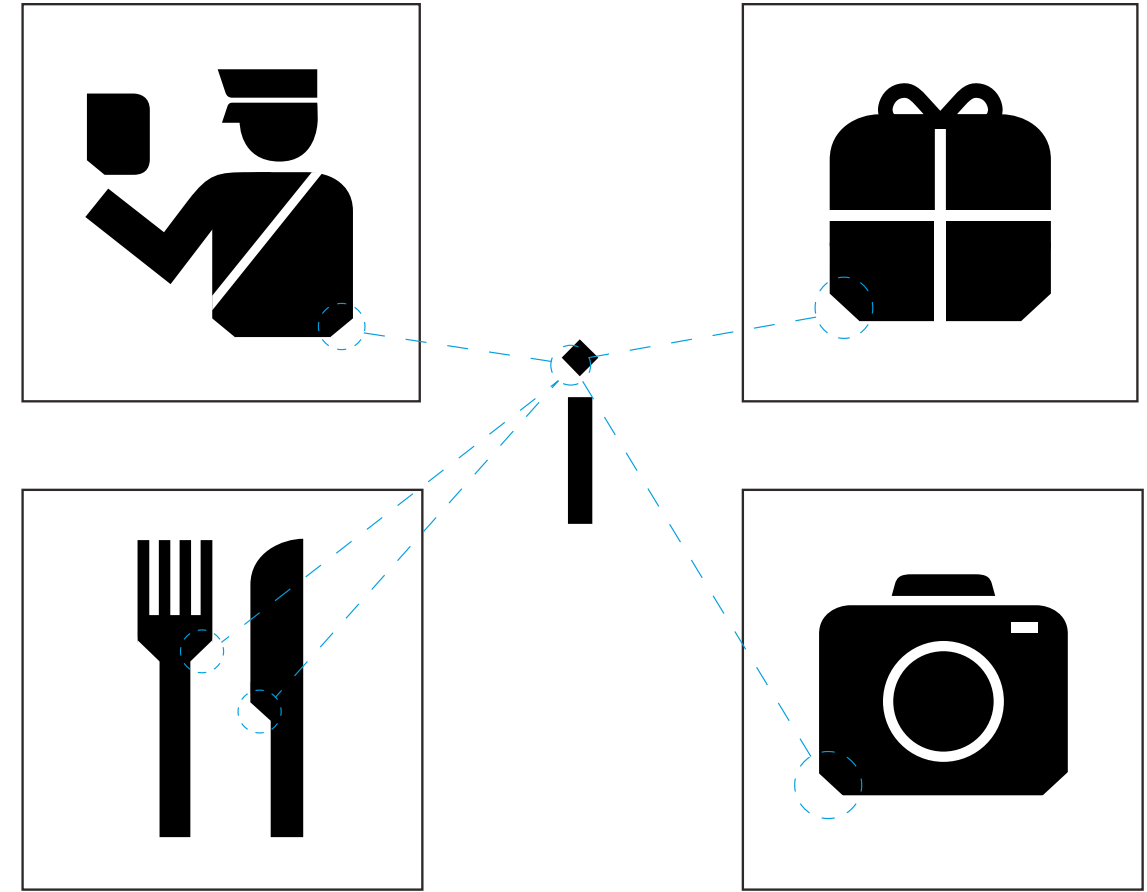

Pictograms

Series of customized pictograms created for the Beirut International Airport as an extension of the typography.

They are drawn to match the details of Fedra Sans.

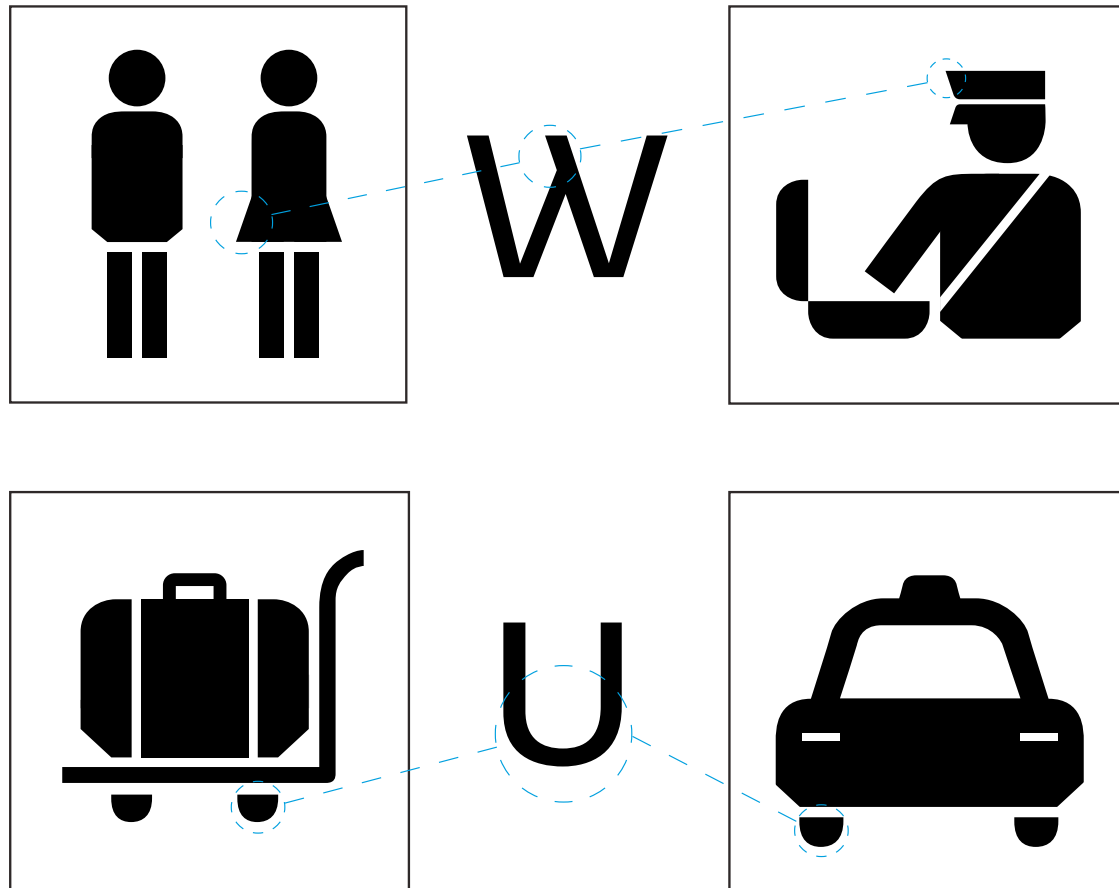

Pictograms

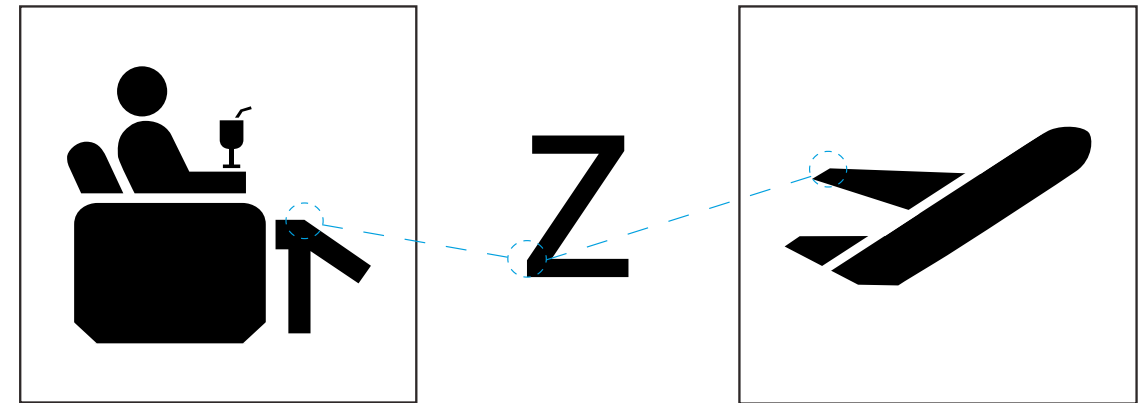

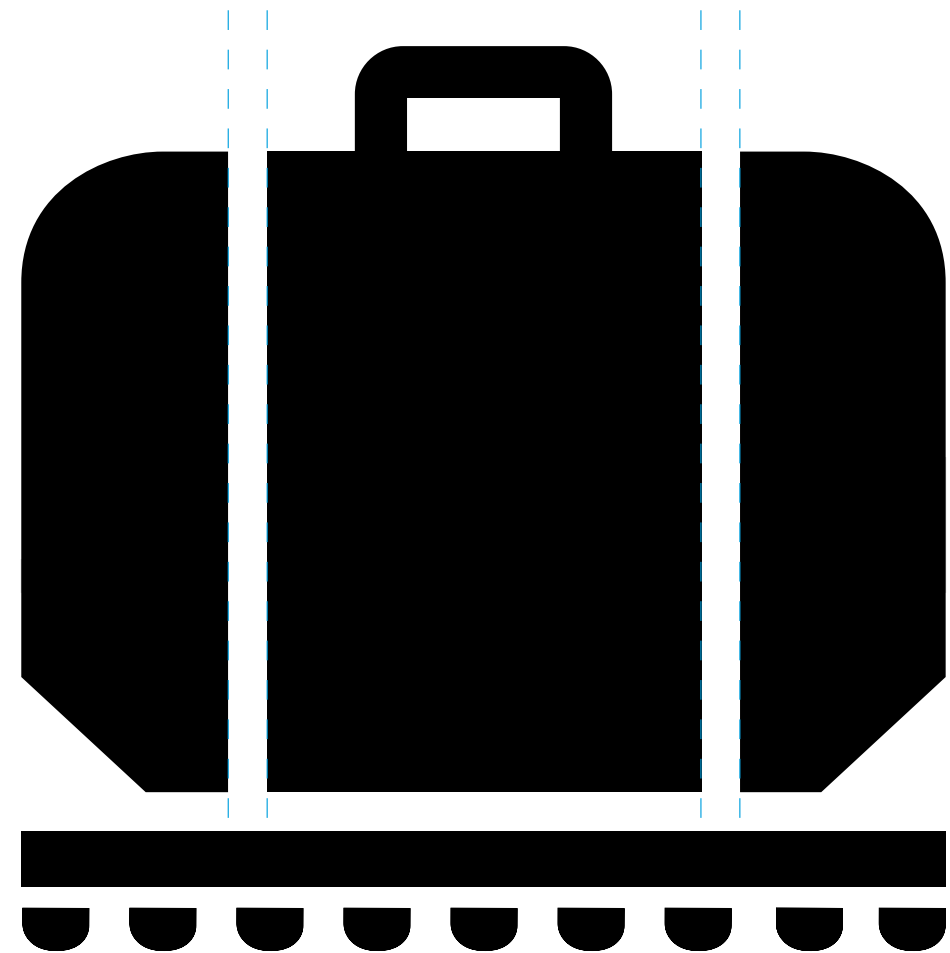
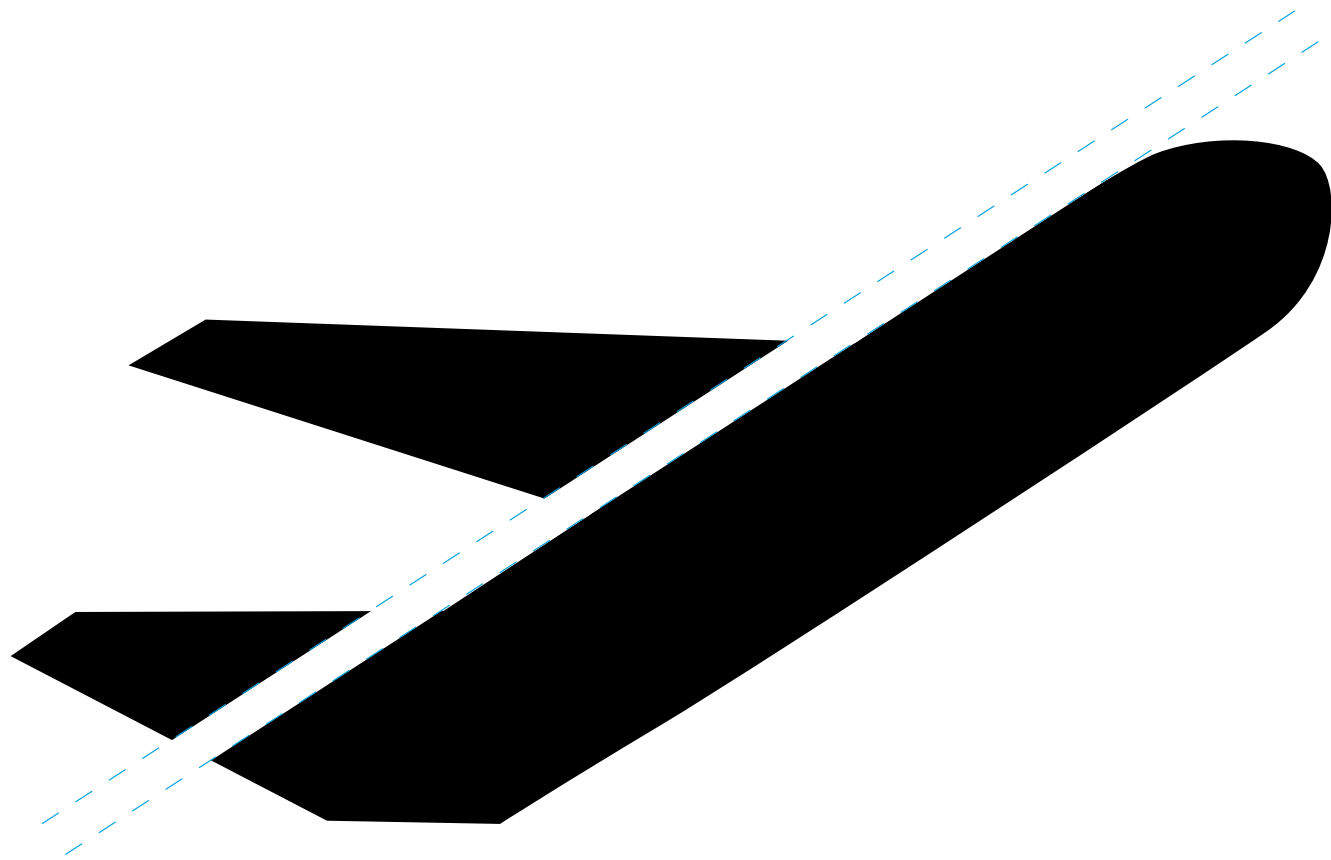

Pictograms

Pictograms centered within the square.
Do not exceed the margins.



Pictograms



Pictograms



Pictograms



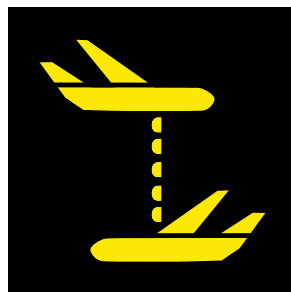
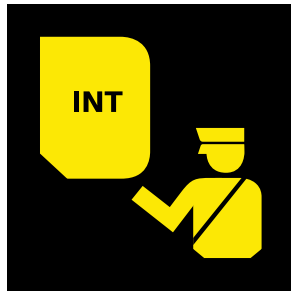

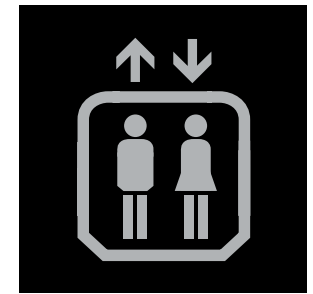
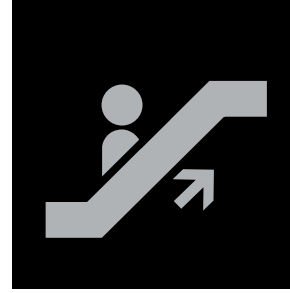
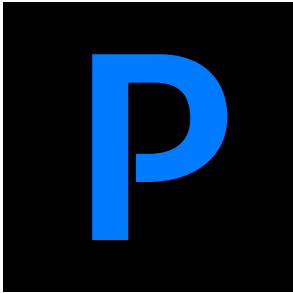

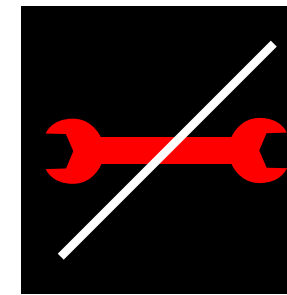
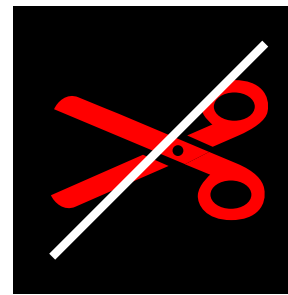
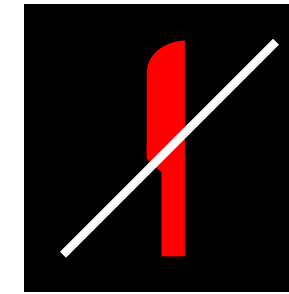
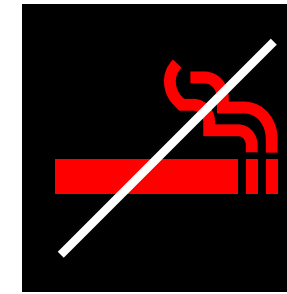
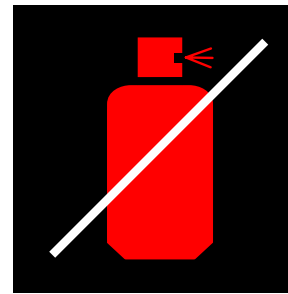
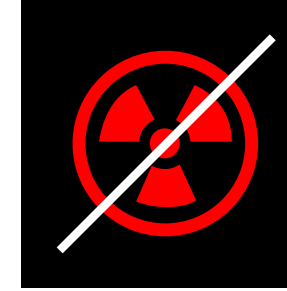
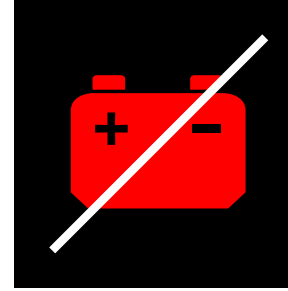
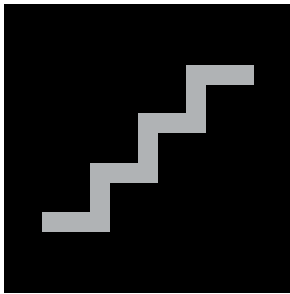
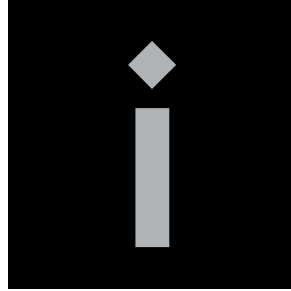
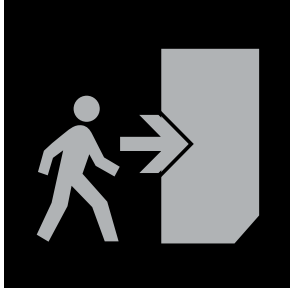

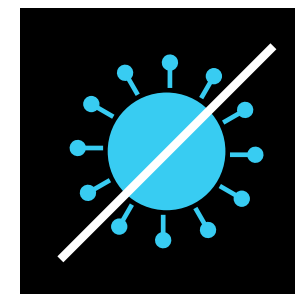
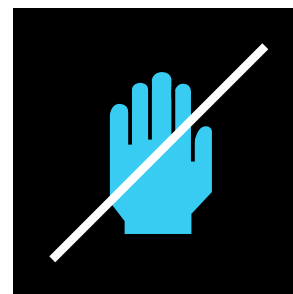
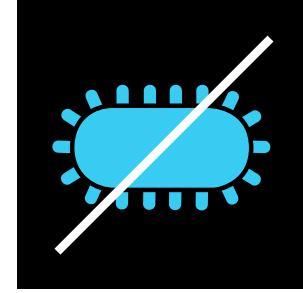
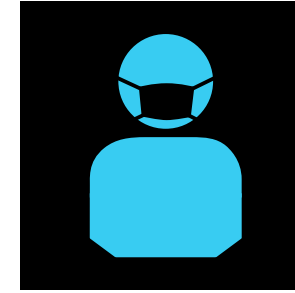
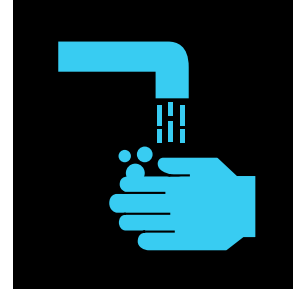
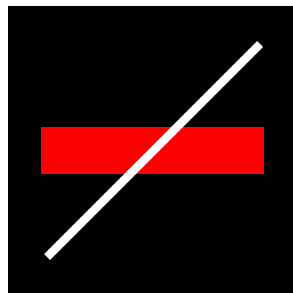
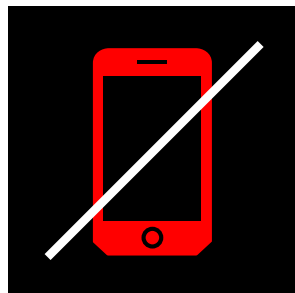
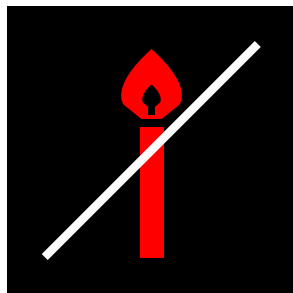

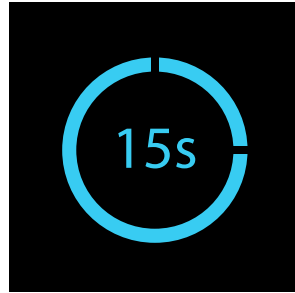
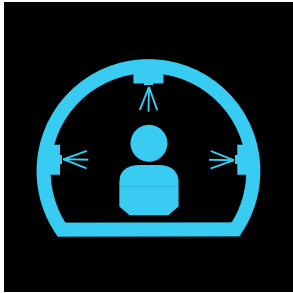
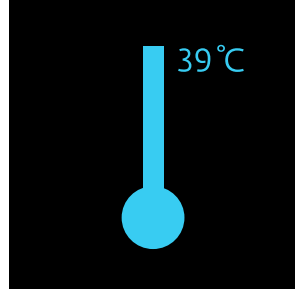
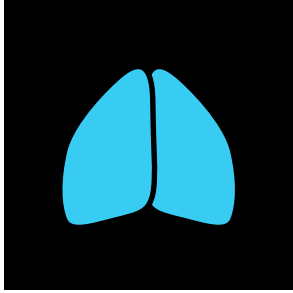

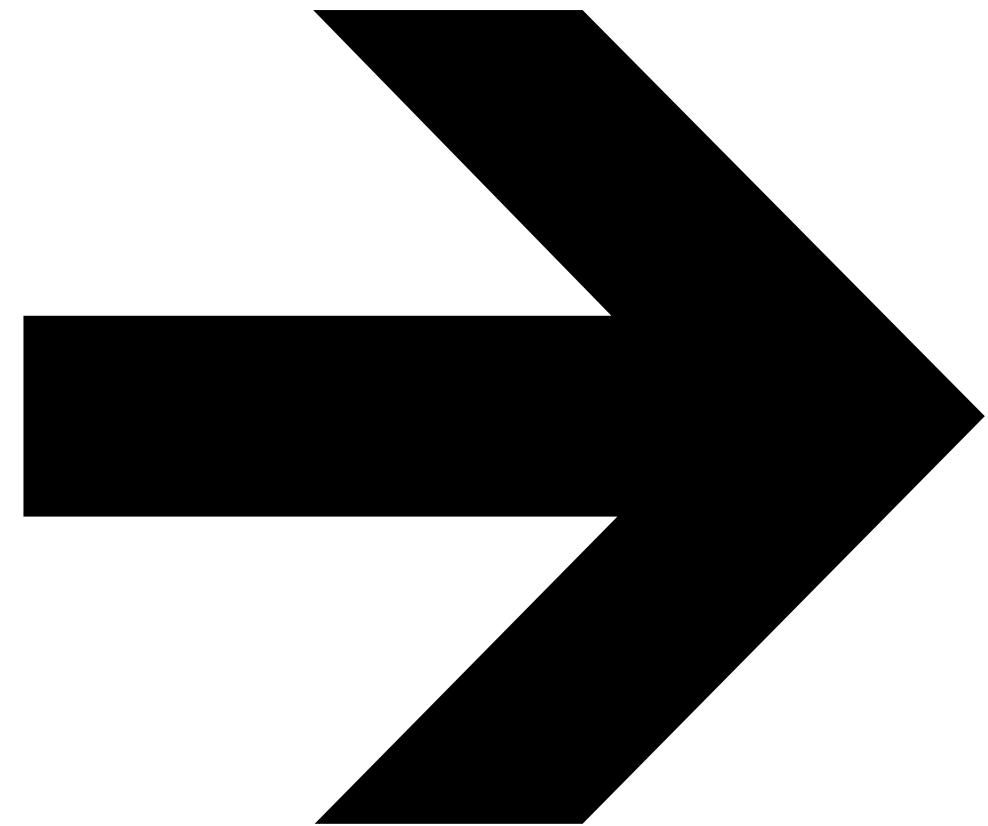
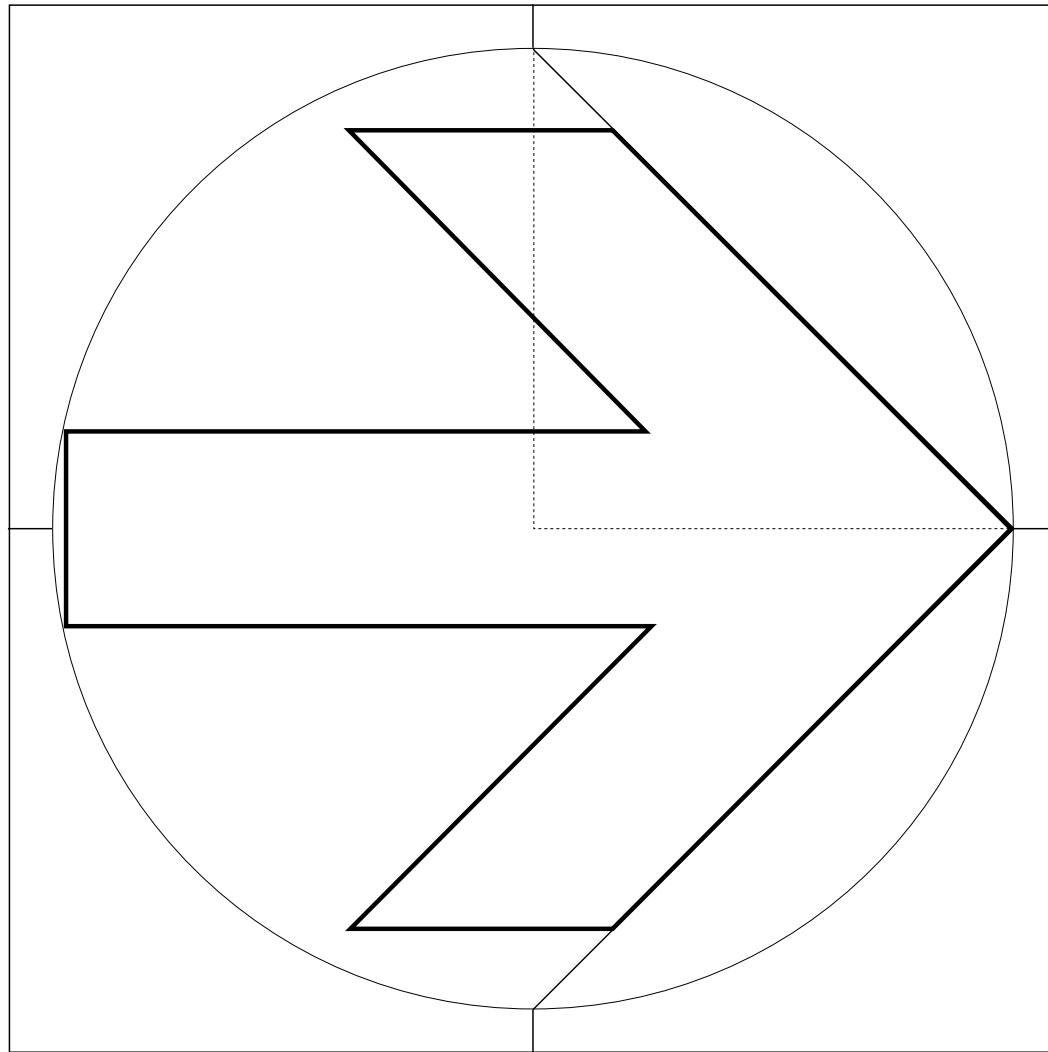

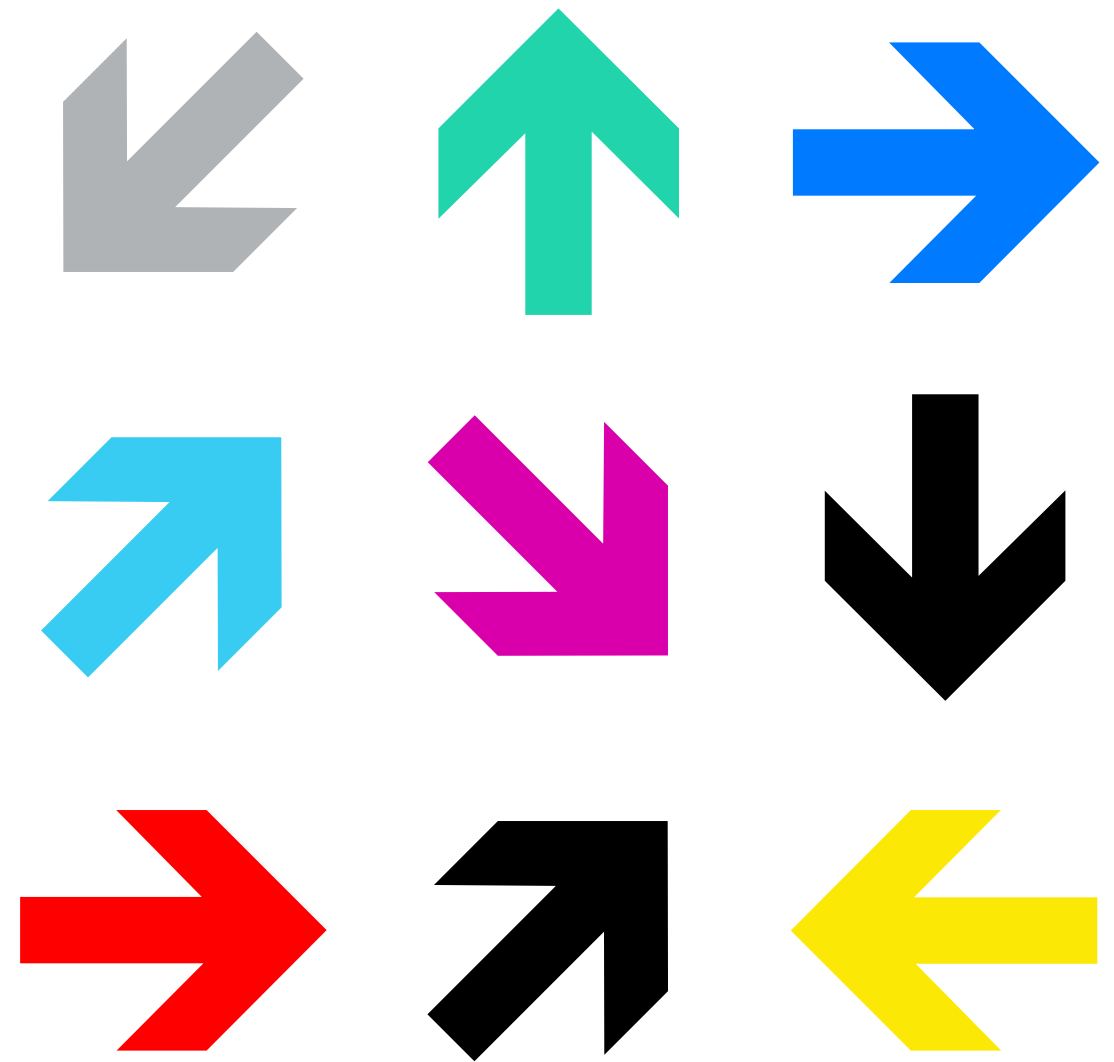
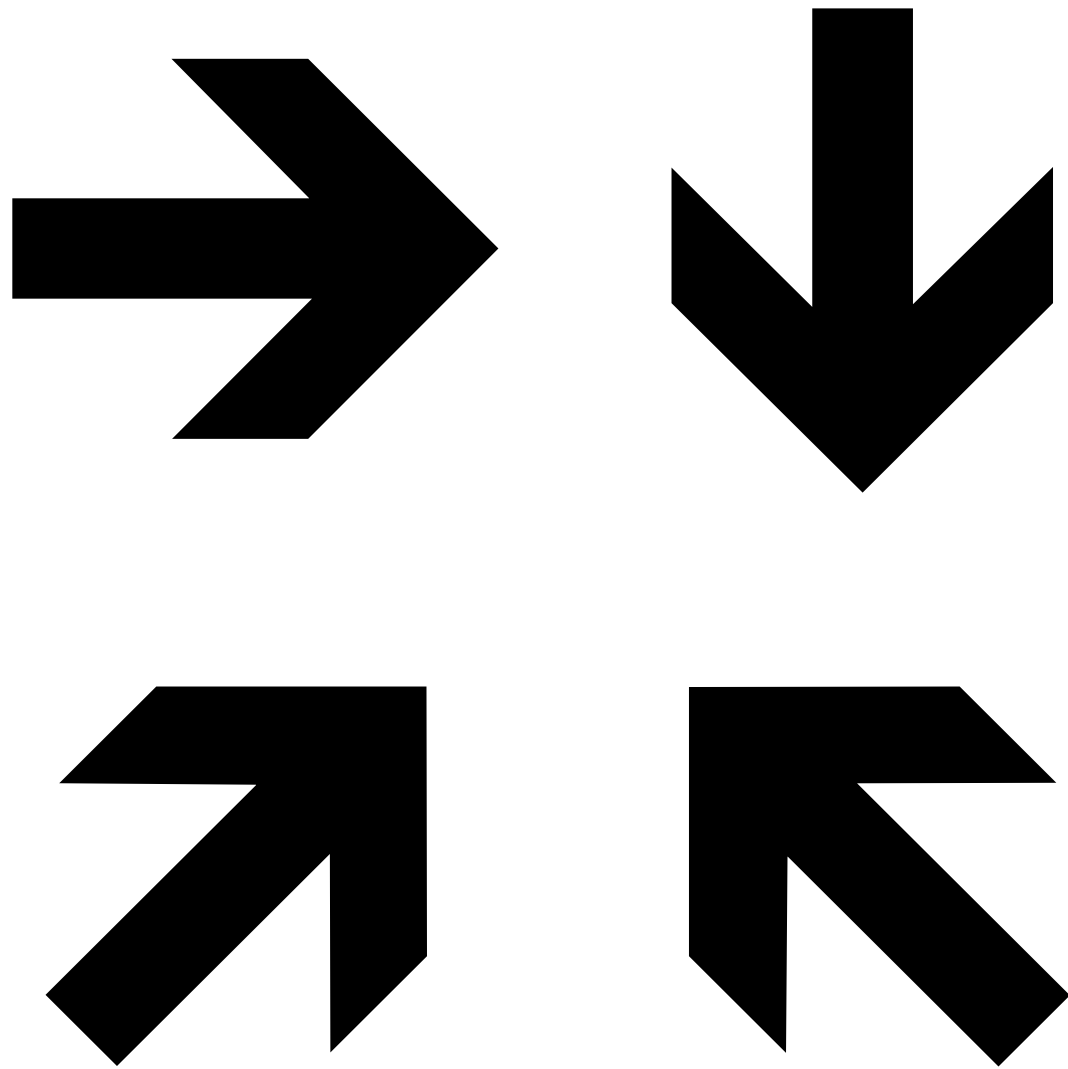

Sign plate modulations

A modular signage system applied on all plates throughout. The system is based on one square module element, that is duplicated as much as needed.

The icon occupies one module, whereas the message occupies 2 modules or more.

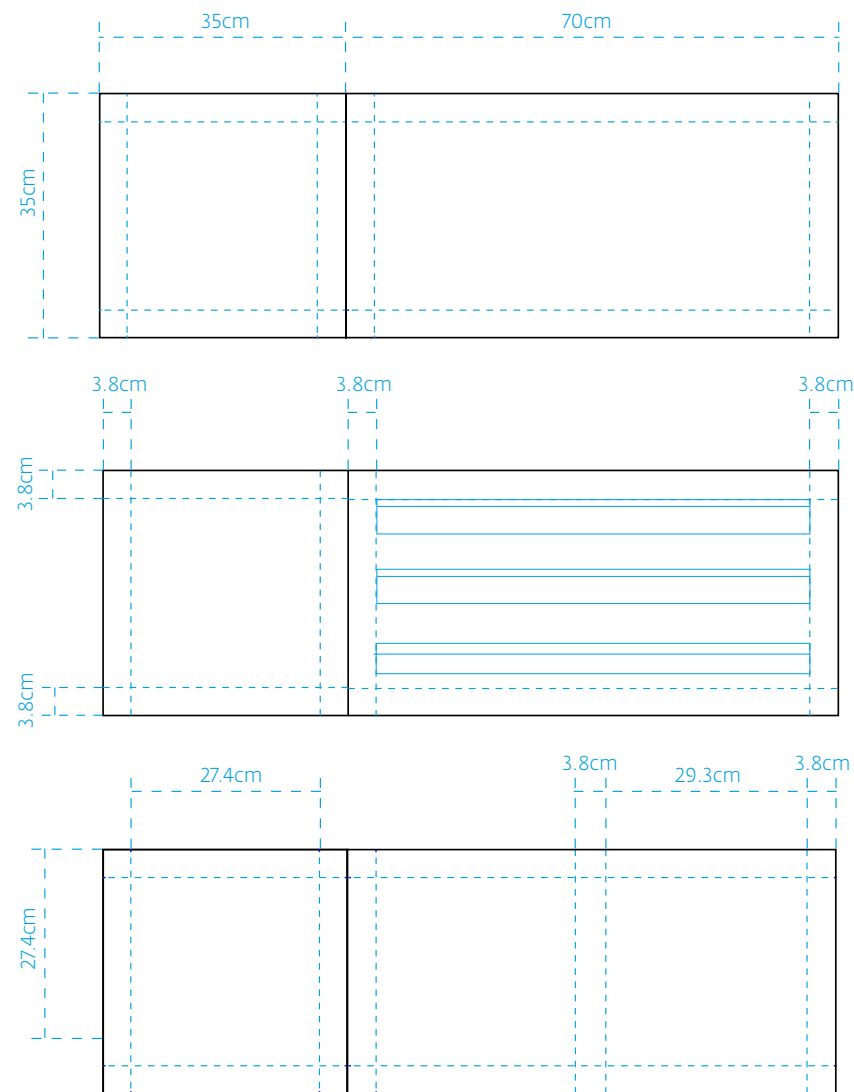

Sign plate modulations

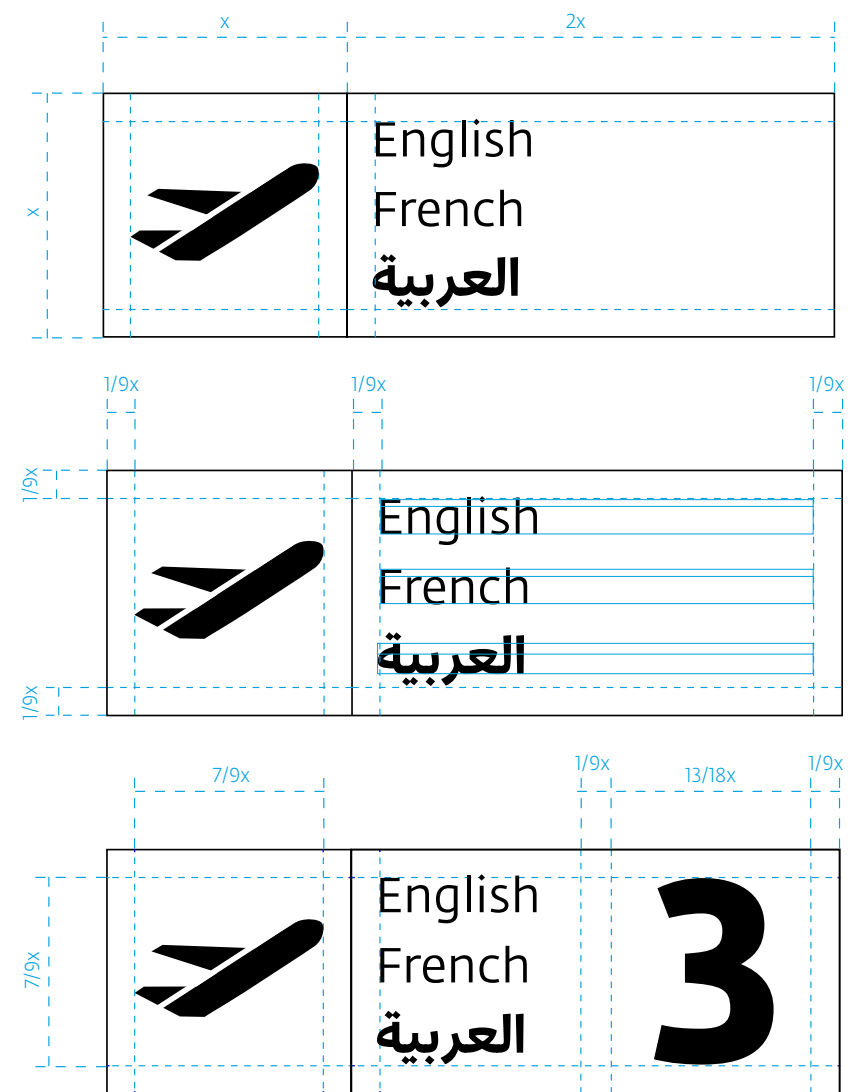

Sign plate modulations

A modular signage system applied on all plates throughout. The system is based on one square module element, that is duplicated as much as needed.

The icon occupies one module, whereas the message occupies 2 modules or more.

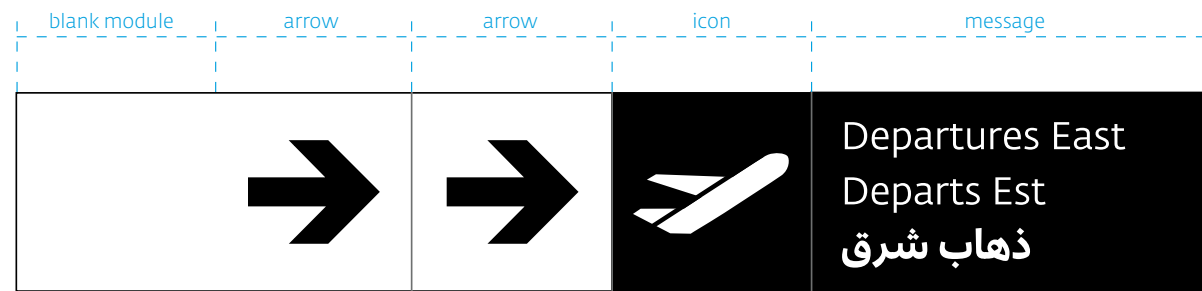
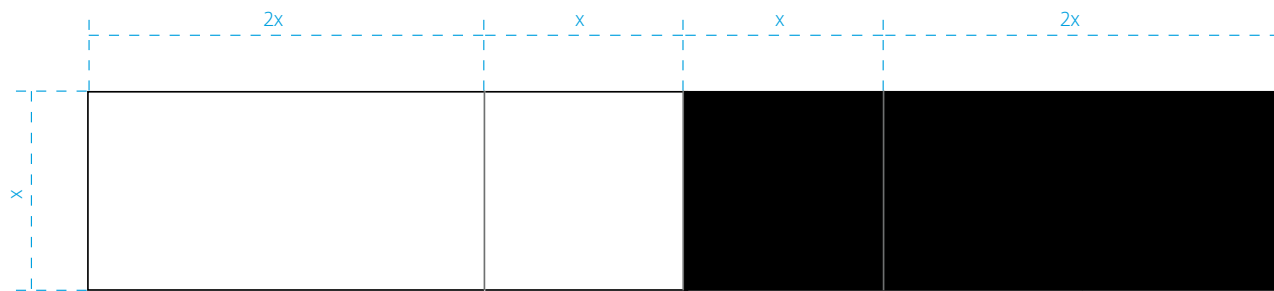

gray thin line separating modules vertically

Sign plate modulations

On a high ceiling, the sign extends vertically. Modules are added under each other.

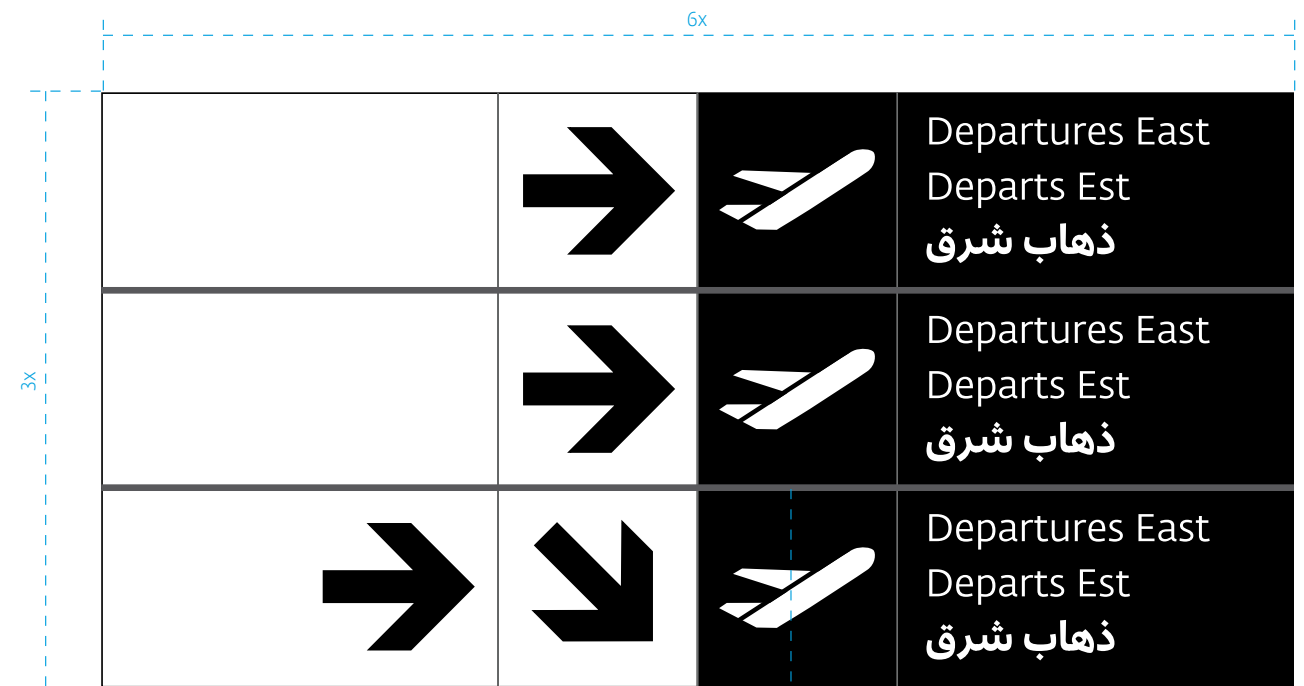

double arrow > closer destination
single arrow > further destination

horizontal groove in the physical sign separating modules

Sign plate modulations

On a low ceiling, the sign extends horizontally. Modules are added next to each other.

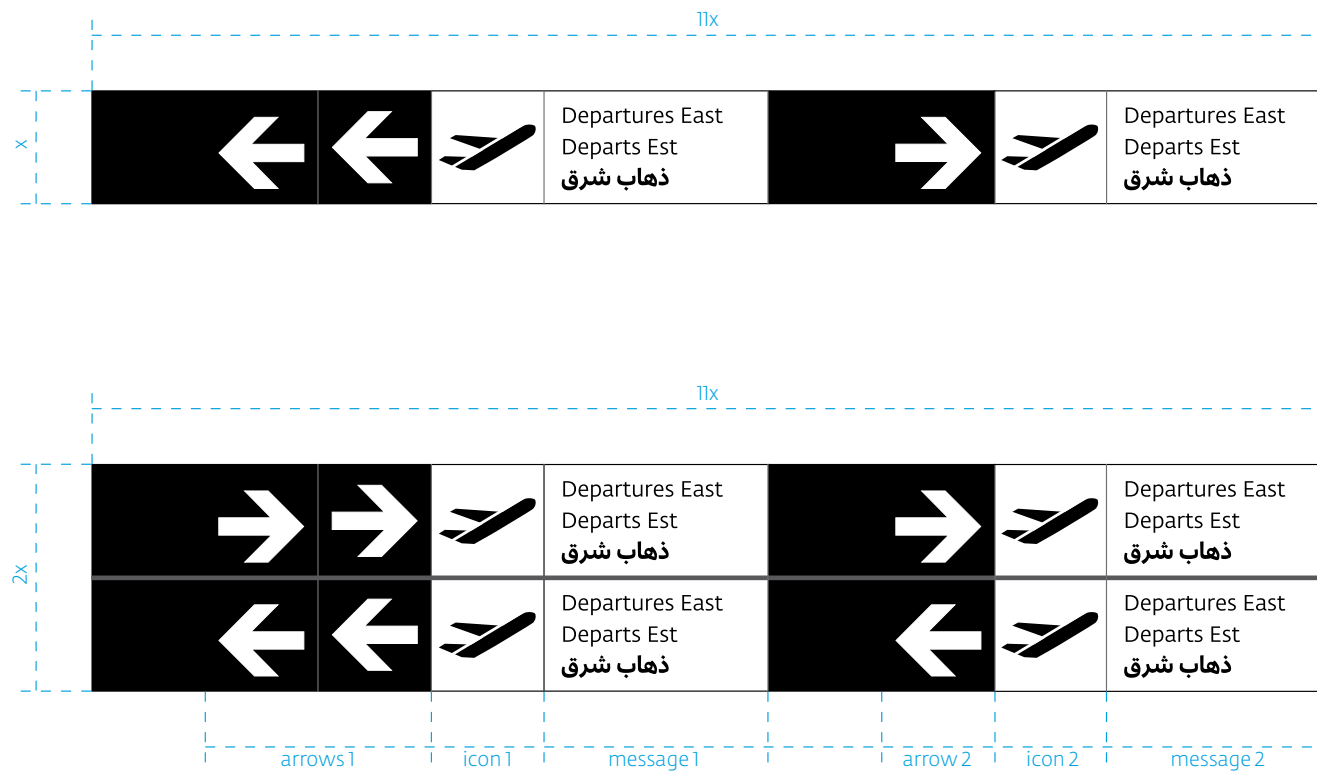

Sign plate modulations

1. Situation directing left to all departures.
2. Directional situation where the exit is to the left as well as to the right.
3. Situation at an intersection, straight ahead

for departure east and right for departure west. When there is a change of direction indicated on the same sign, there should be a blank module to separate the 2 directions and avoid confusion.

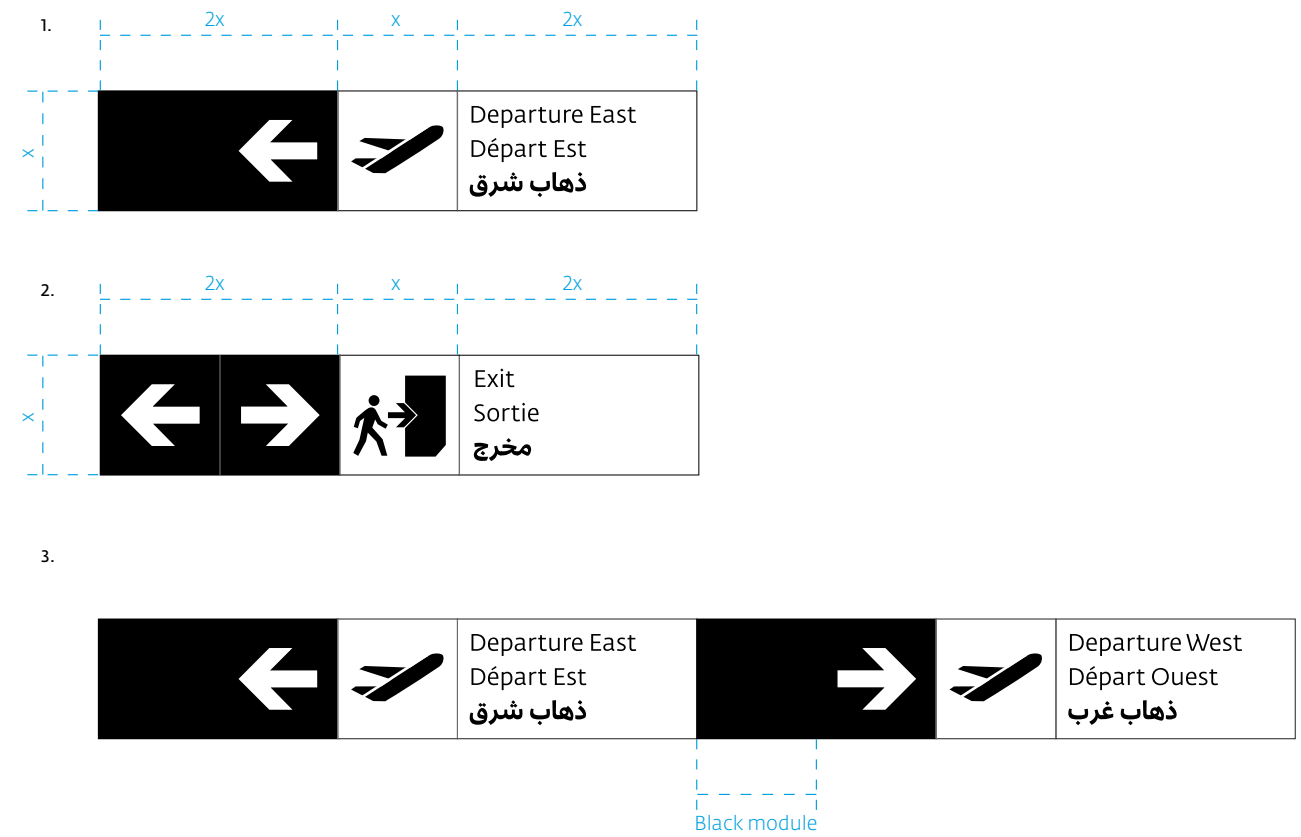

V- SIGNAGE AND ENVIRONMENTAL DESIGN IMPLEMENTATIONS

Sign type, shape and function

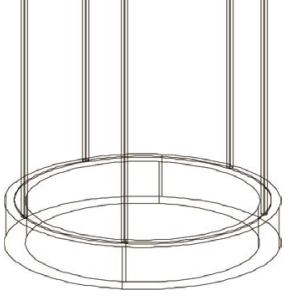
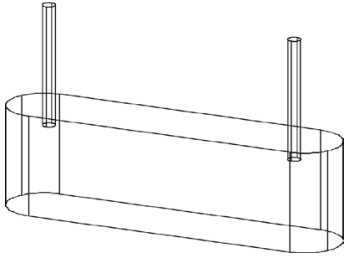
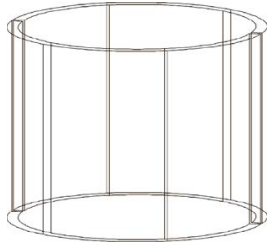

The signs shape complement the spatial architecture of the Airport.
DIR-Cylindric is found twice in the Airport. In the main entrance and in the central area of the

Duty-free.
ID/DIR-squircle is used almost everywhere in the Airport and especially in walkways.

SHAPE	CODE NAME	FUNCTION
	DIR-CYLINDRIC	DIRECTIONAL
	DIR-SQUIRCLE ID-SQUIRCLE	DIRECTIONAL IDENTIFICATION
	ID-WRAP	IDENTIFICATION

Sign type, shape and function

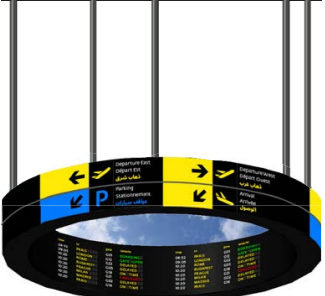
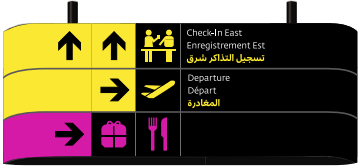
ID-Wrap is used when needed, wrapping around the existing structural poles.



POSITIONING	LOCATION	EXAMPLE
CEILING MOUNTED	MAIN ENTRANCE DUTY FREE	
CEILING MOUNTED	WALKWAYS	
POLE MOUNTED FULL / HALF / 1/4	EXTERIOR AND INTERIOR POLES	

Sign type, shape and function

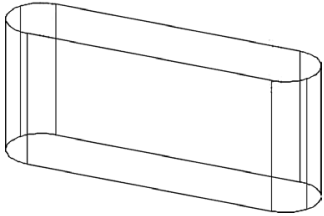
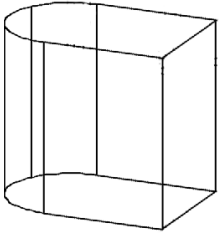
ID/REG-Half and ID/REG-Mounted are mounted on doors or walls, when there is no poles. They are used for regulatory, toilets, information...
INF-Stand is found at 3 moments in the Airport; Parking, Entrance and Duty-free.

SHAPE	CODE NAME	FUNCTION
	INF-STAND	INFORMATIONAL
	ID-MOUNTED REG-MOUNTED	IDENTIFICATION REGULATORY
	ID-HALF REG-HALF	IDENTIFICATION REGULATORY

Sign type, shape and function

POSITIONING	LOCATION	EXAMPLE
FREE-STANDING	PARKING MAIN ENTRANCE DUTY FREE	
WALL / DOOR MOUNTED	INTERNAL BLDG WALLS AND POLES	
WALL / DOOR MOUNTED	INTERNAL BLDG WALLS AND POLES	

Family shot

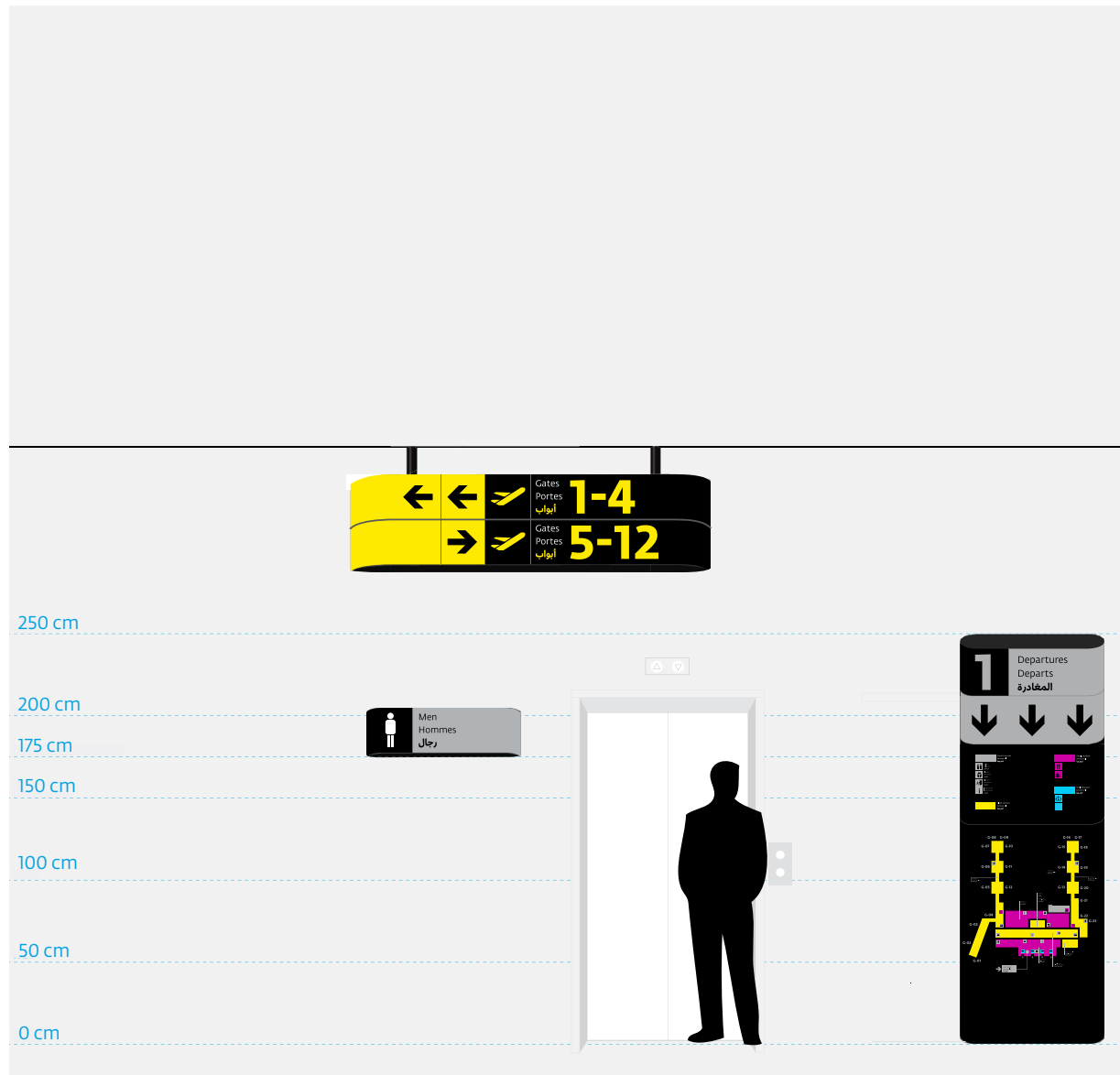

Family shot

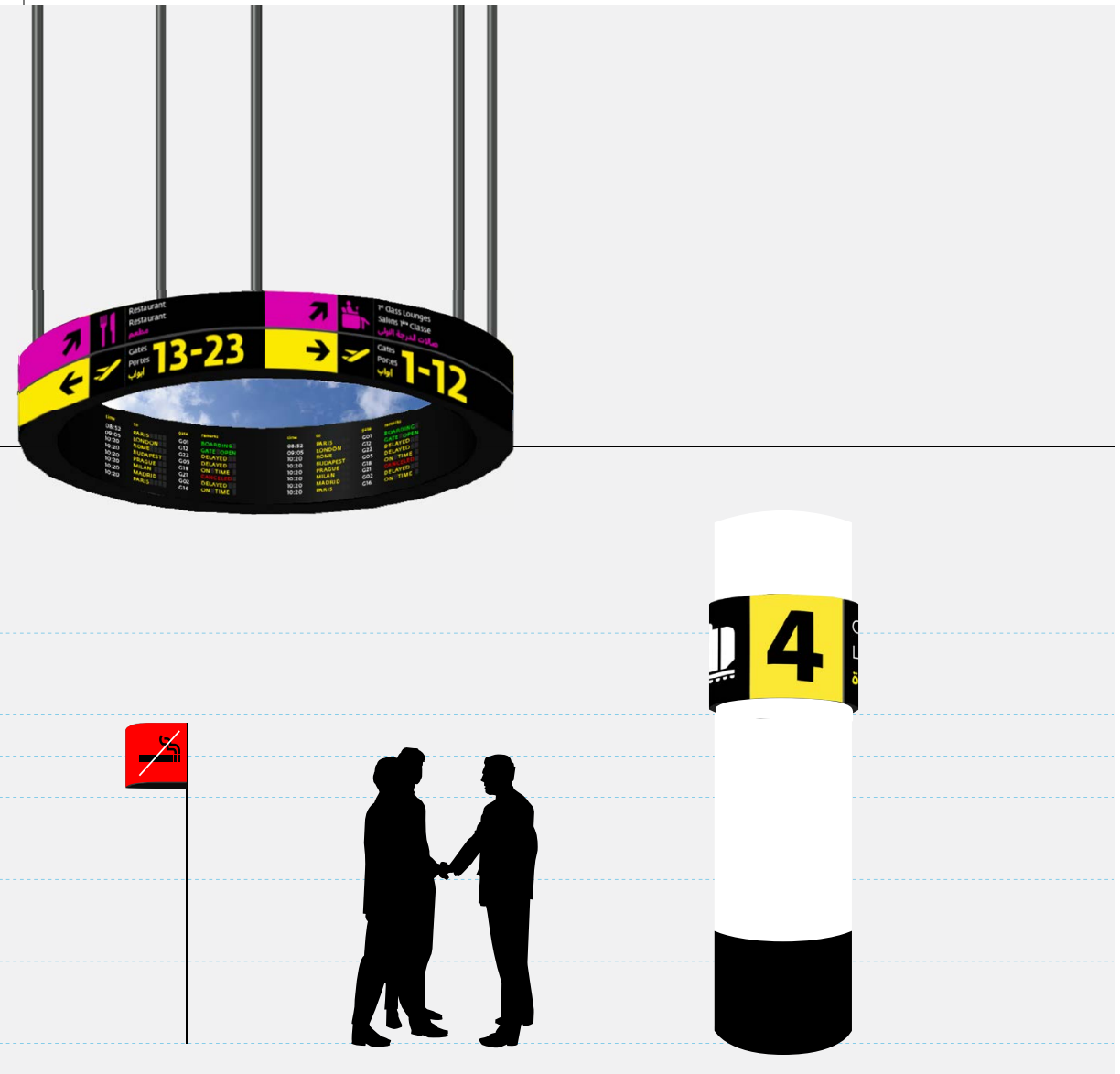

DIR. | ID. | INF. | REG.

DIRECTIONAL SIGNAGE

DIR. | ID. | INF. | REG.
Sign shape, plate & 3D adaptation

DIR-Cylindric is found twice in the Airport, in the Main entrance and in the central area of the Duty-free. It needs to be placed in a context of high ceiling and wide space (information on 360°)

All signs are made of Black Matte Arylic. Graphics are direct printed using Flat-bed printing.

DIR-Cylindric Wireframe front view

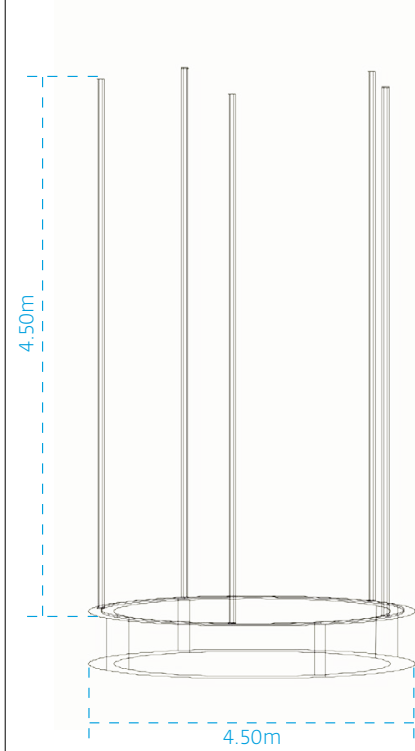

DIR-Cylindric 3D bottom view



DIR-Cylindric 3D top view

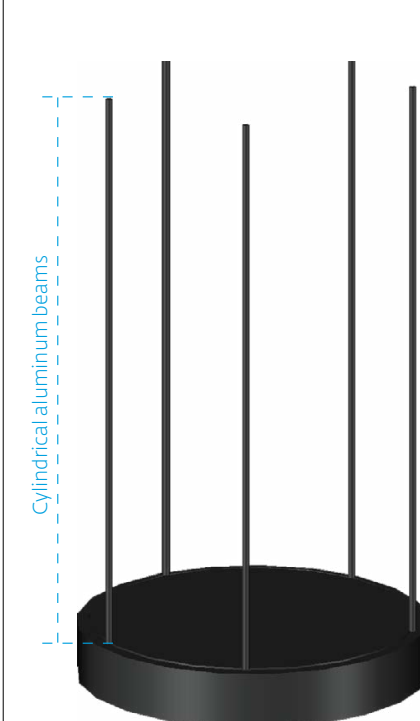

DIR. | ID. | INF. | REG.
Sign shape, plate & 3D adaptation

To differentiate between the directional and identification sign that has the same shape, the background colors switch (check below).

Colored background
Black arrow

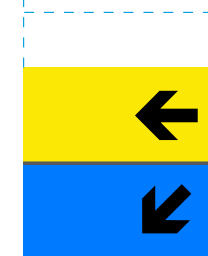

Black background
White/Yellow message

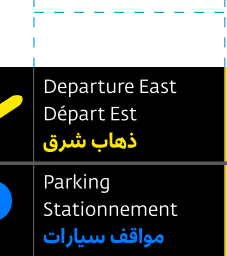

Black background
Yellow pictogram

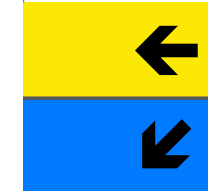

Digital flight board

time	to	gate	remarks	time	to	gate	remarks
08:52	PARIS	G01	BOARDING	08:52	PARIS	G01	BOARDING
09:05	LONDON	G12	GATE OPEN	09:05	LONDON	G12	GATE OPEN
10:20	ROME	G22	DELAYED	10:20	ROME	G22	DELAYED
10:20	BUDAPEST	G05	DELAYED	10:20	BUDAPEST	G05	DELAYED
10:20	PRAGUE	G18	ON TIME	10:20	PRAGUE	G18	ON TIME
10:20	MILAN	G21	CANCELED	10:20	MILAN	G21	CANCELED
10:20	MADRID	G02	DELAYED	10:20	MADRID	G02	DELAYED
10:20	PARIS	G16	ON TIME	10:20	PARIS	G16	ON TIME

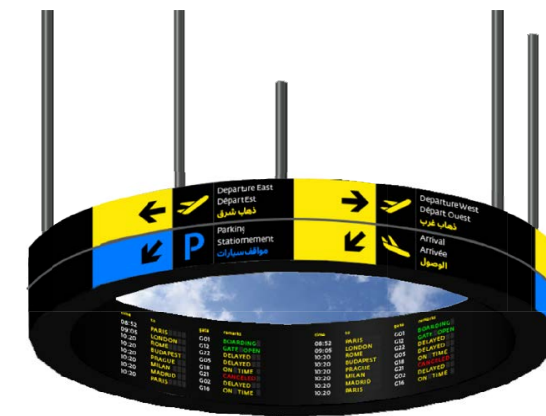

DIR. | ID. | INF. | REG.
Sign shape, plate & 3D adaptation

The signs below represent the 2 "masterpieces" of the Airport that serve as key reference points.

1. DIR-Cylindric in the main entrance

		Departure East Départ Est ذهاب شرق			Departure West Départ Ouest ذهاب غرب
		Parking Stationnement مواقف سيارات			Arrivée الوصول

1.

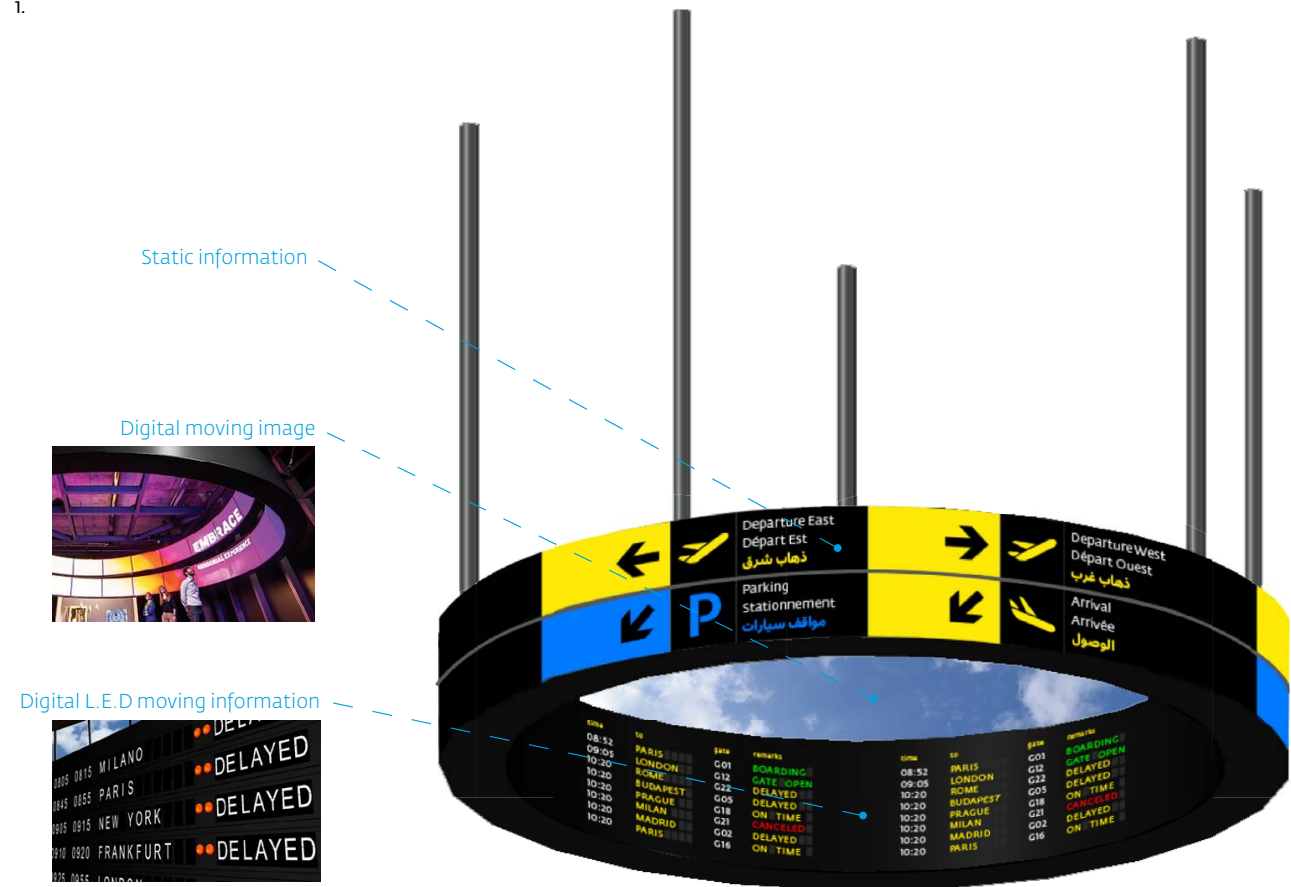

Static information

Digital moving image

Digital L.E.D moving information

DIR. | ID. | INF. | REG.
Sign shape, plate & 3D adaptation

2. DIR-Cylindric in the center of Duty Free

		Restaurant Restaurant مطعم			1 st Class Lounges Salons 1 ^{re} Classe صالات الدرجة الاولى
		Gates Portes ابواب 13-23			Gates Portes ابواب 1-12

2.

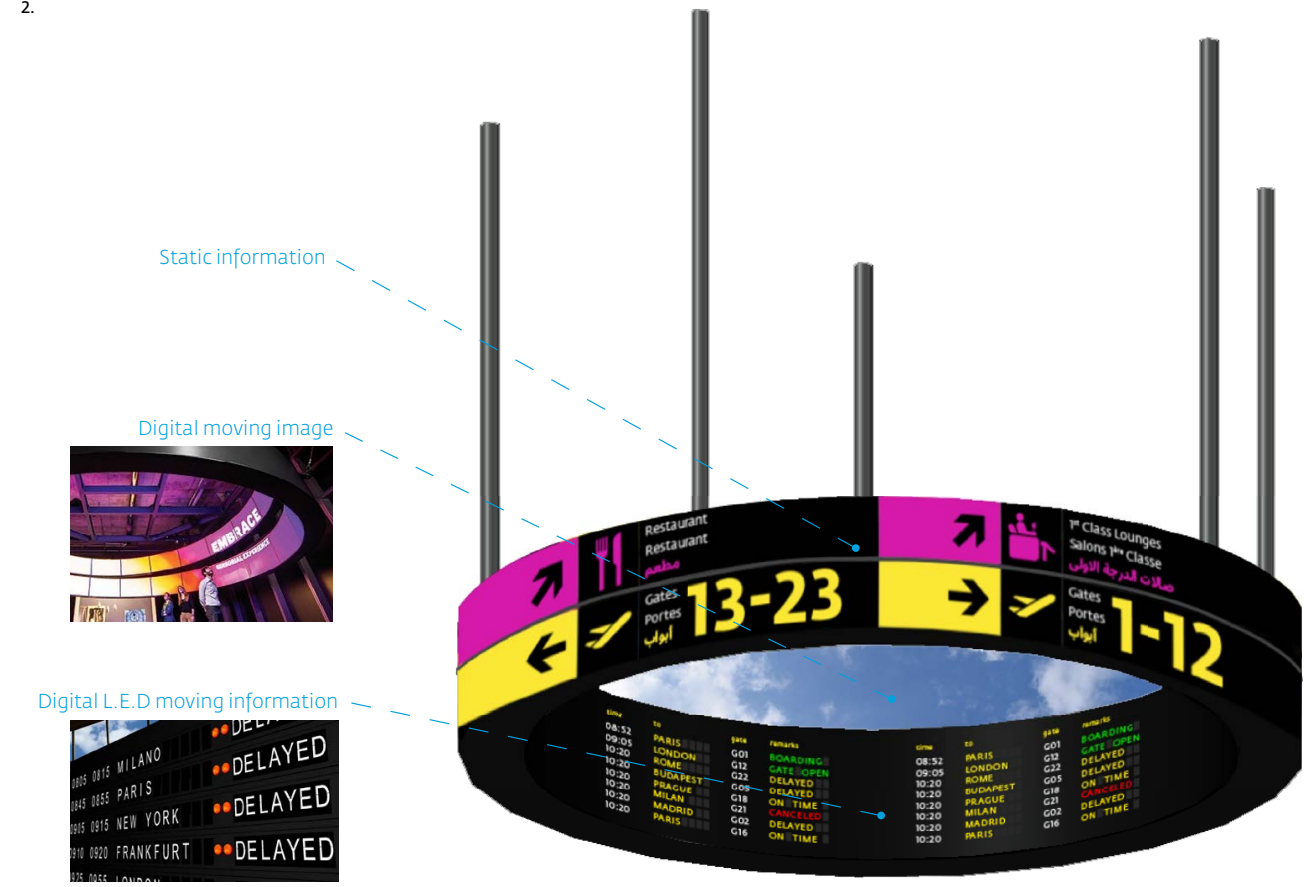

Static information

Digital moving image

Digital L.E.D moving information

DIR. | ID. | INF. | REG.
Sign shape, plate & 3D adaptation

DIR-Squircle is found almost everywhere in the Airport and especially in walkways.

Customizable modules leading to different heights/lengths.
Based on one module 35x35cm.

DIR-Squircle
3D side/top view
Variable: Customizable module
-1 module > 35X35cm
-Variable length

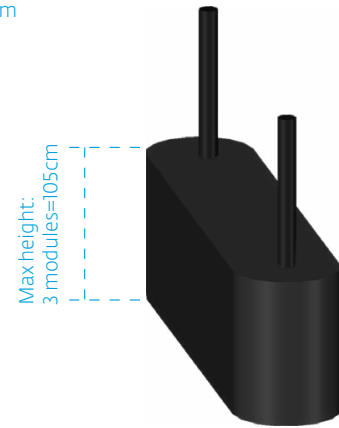

DIR-Squircle
Wireframe front view

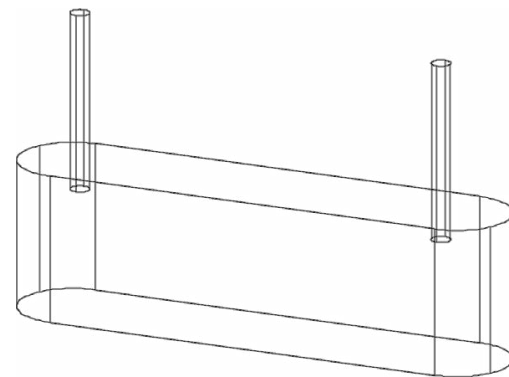

DIR-Squircle
3D front/bottom view

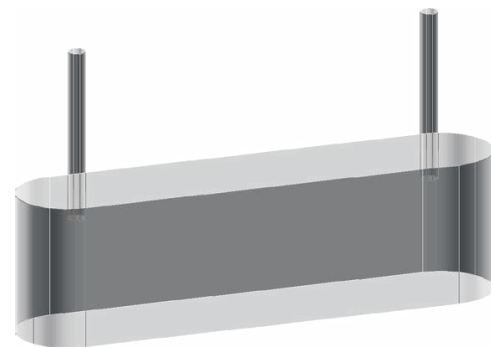

DIR-Squircle
3D side/bottom view

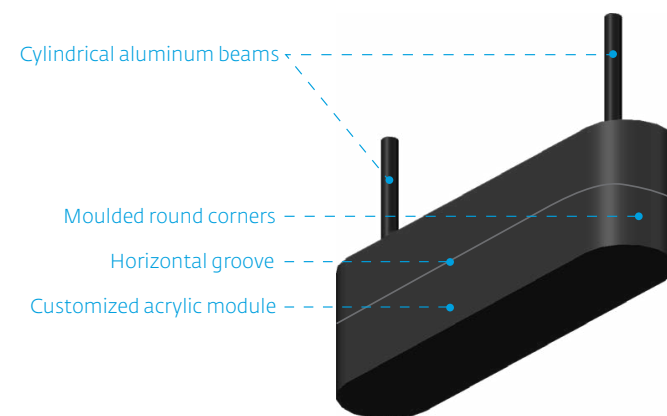

DIR. | ID. | INF. | REG.
Sign shape, plate & 3D adaptation

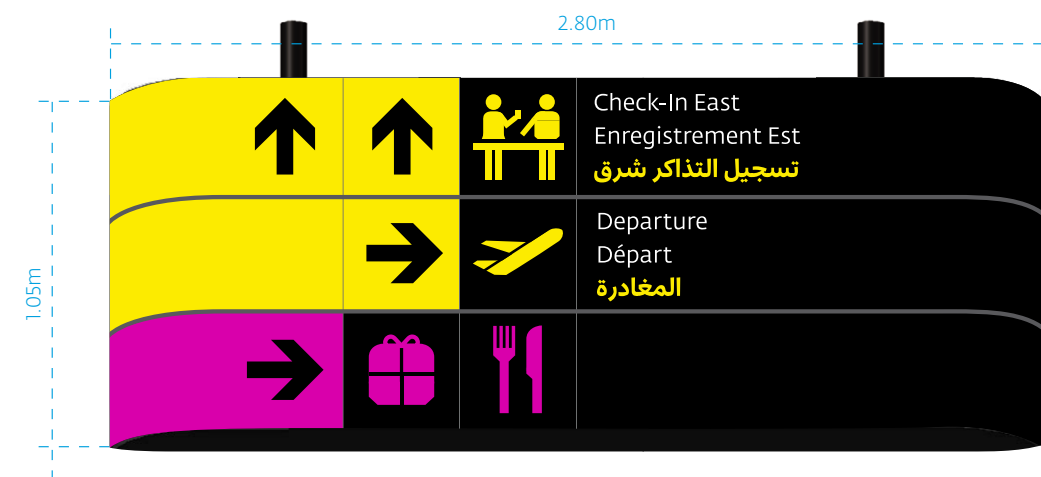
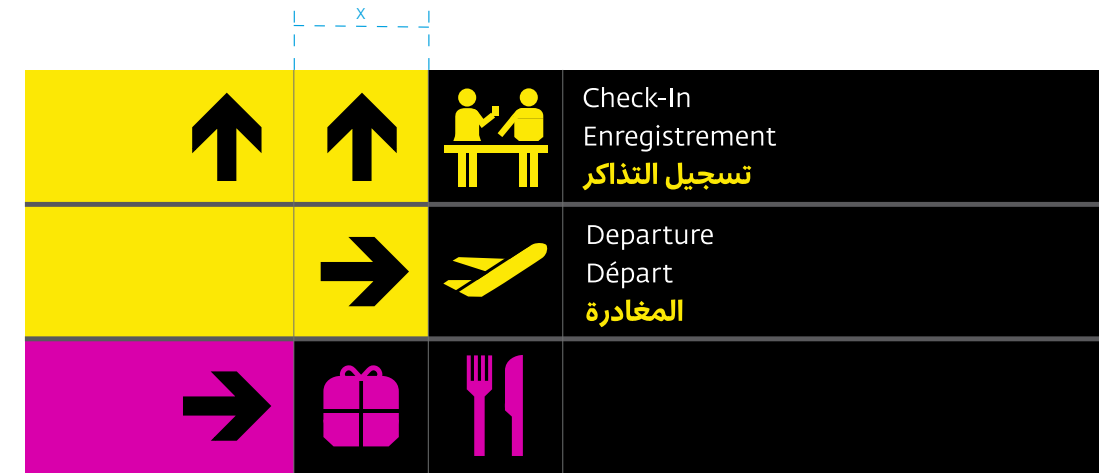



The customs desks are customized depending on the passenger's type of passport; Lebanese passport, Foreign passport or Diplomatic passport.

Lights are placed above the desks in order to indicate whether it is occupied or free.



DIR. | ID. | INF. | REG.
Sign shape, plate & 3D adaptation



DIR. | ID. | INF. | REG.
Sign shape, plate & 3D adaptation





DIR. | ID. | INF. | REG.
Sign shape, plate & 3D adaptation

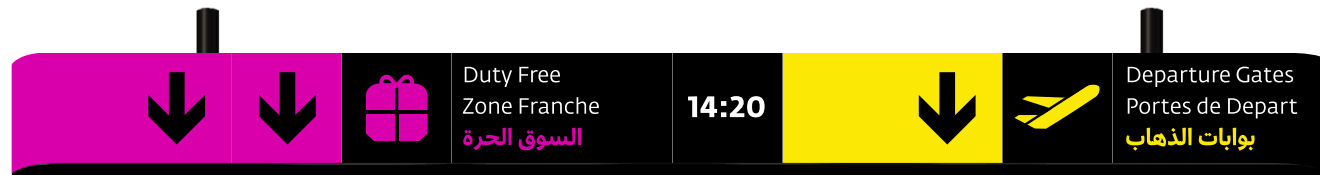
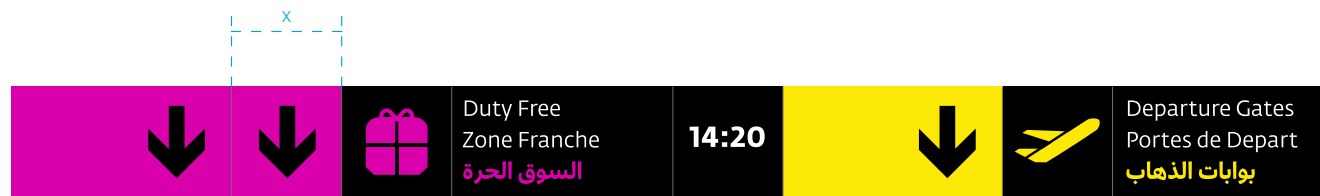

DIR. | ID. | INF. | REG.
Sign shape, plate & 3D adaptation



DIR. | ID. | INF. | REG.
Sign shape, plate & 3D adaptation

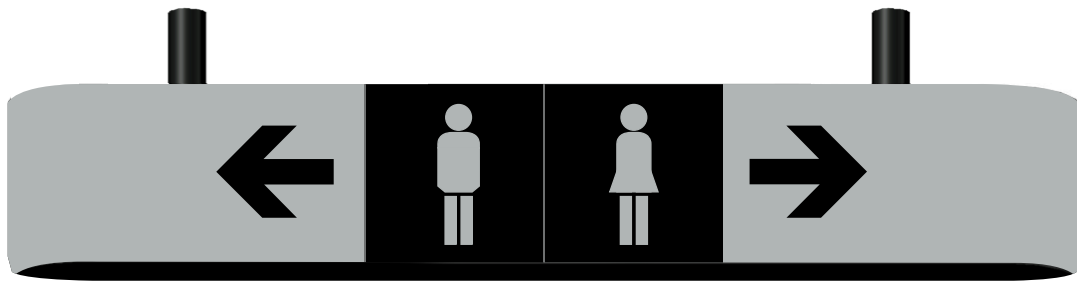
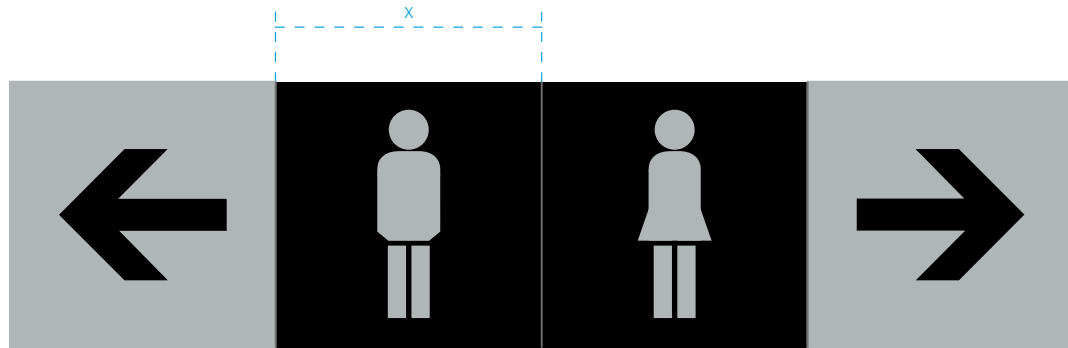

DIR. | ID. | INF. | REG.
Sign shape, plate & 3D adaptation

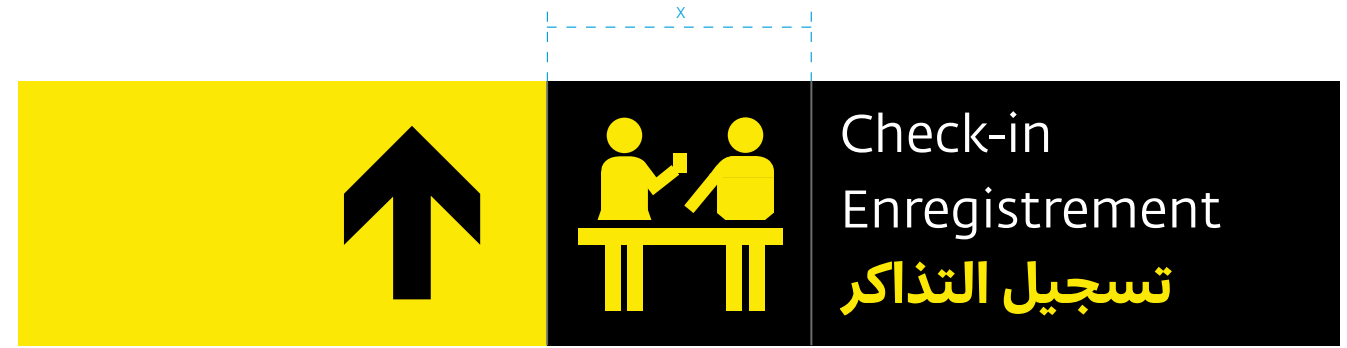

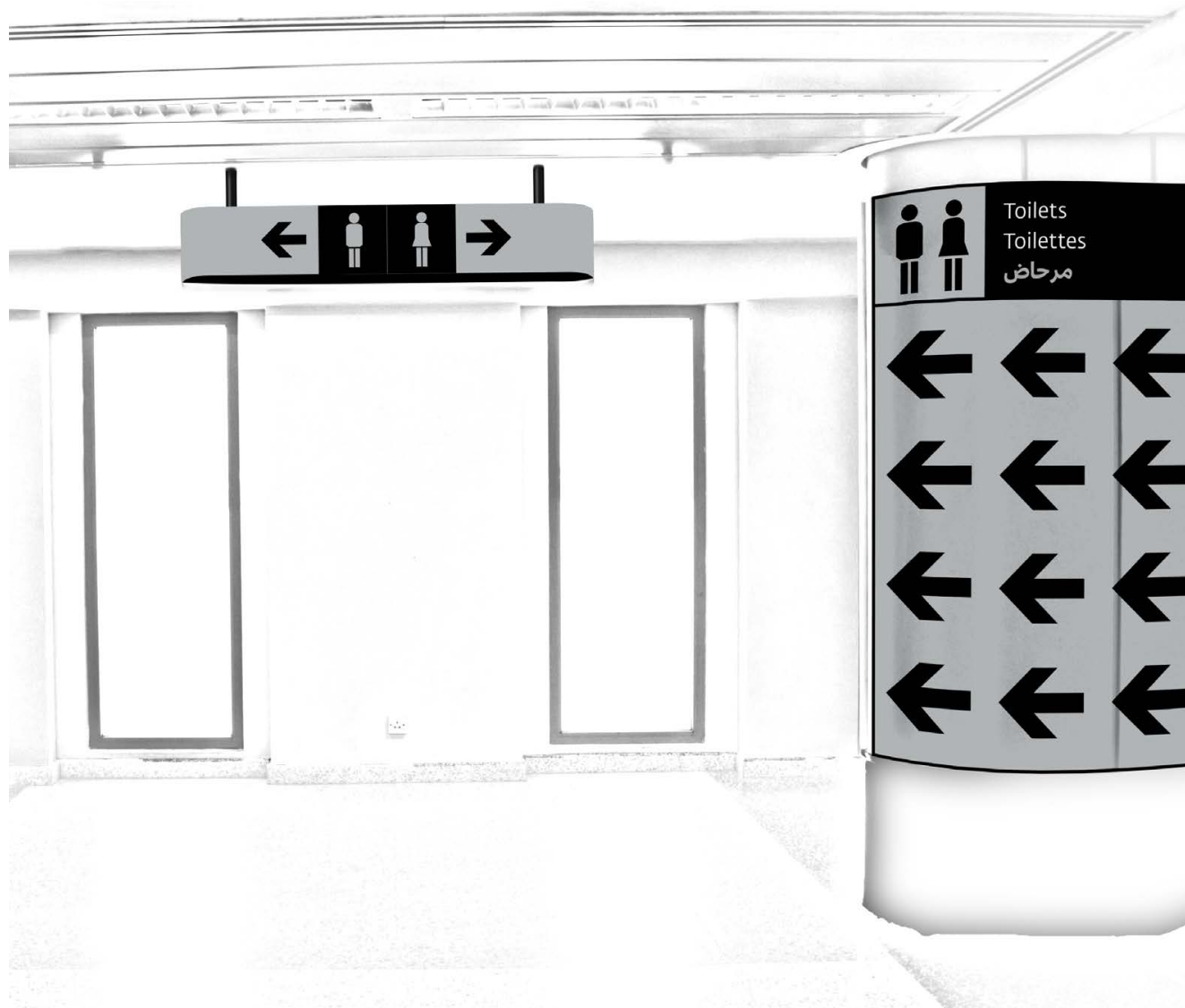

DIR. | ID. | INF. | REG.
Sign shape, plate & 3D adaptation

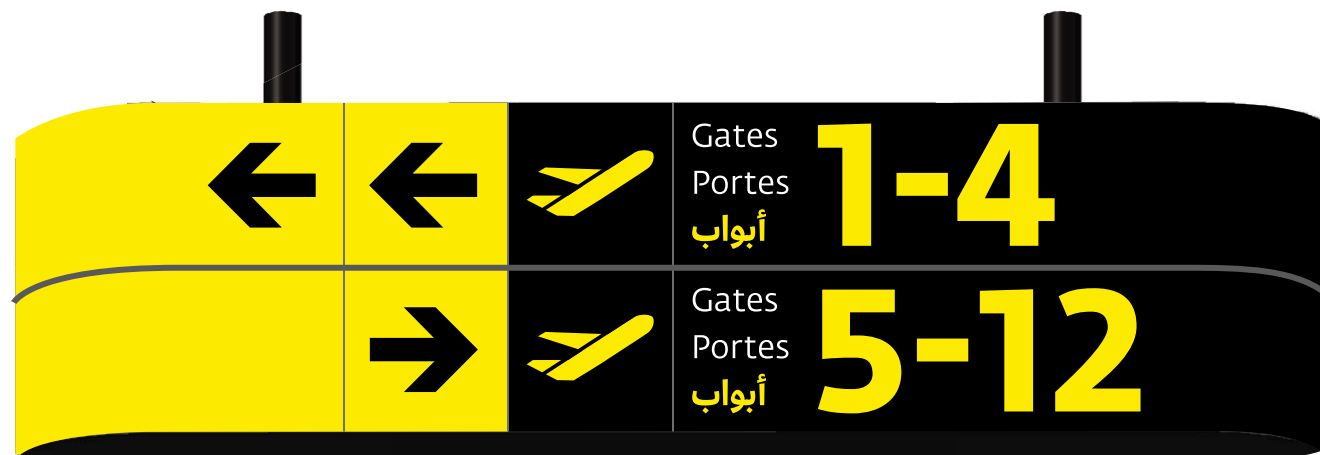

DIR. | ID. | INF. | REG.
Sign shape, plate & 3D adaptation





Wall environmental graphics customized to contribute to the signage system, following the same system and modular logic.

icon on the left

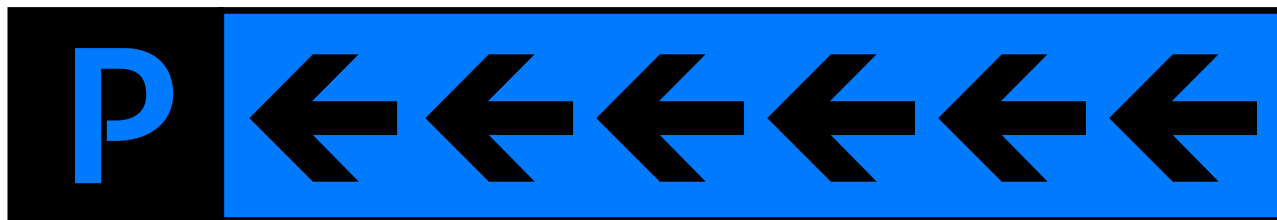
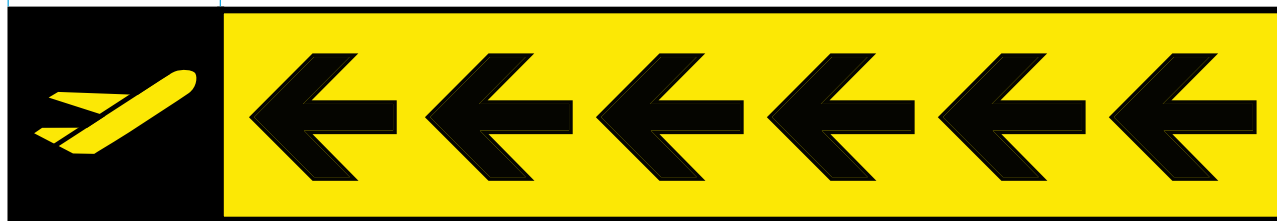

x

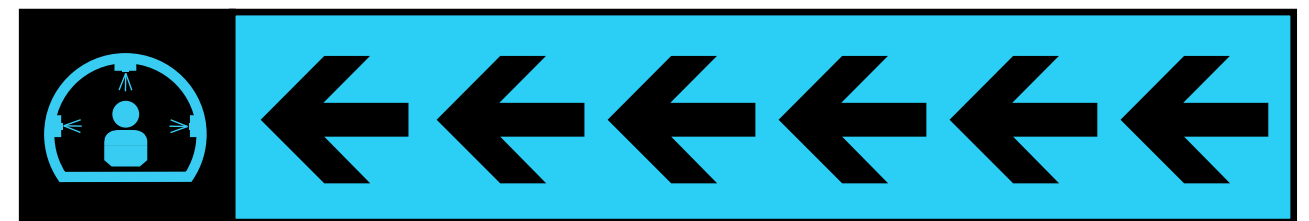
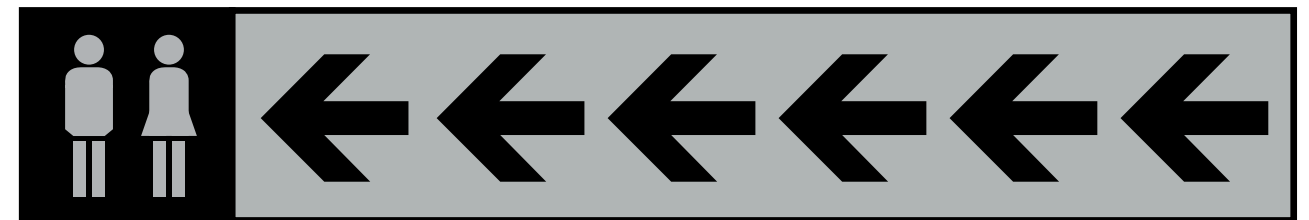
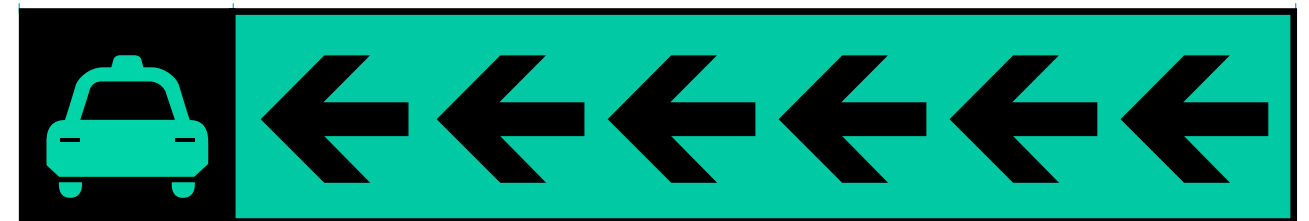

The environmental graphics take the background color of the wall. The size of the square module is adjustable depending on the surface where it is placed (wall, pole, door...)

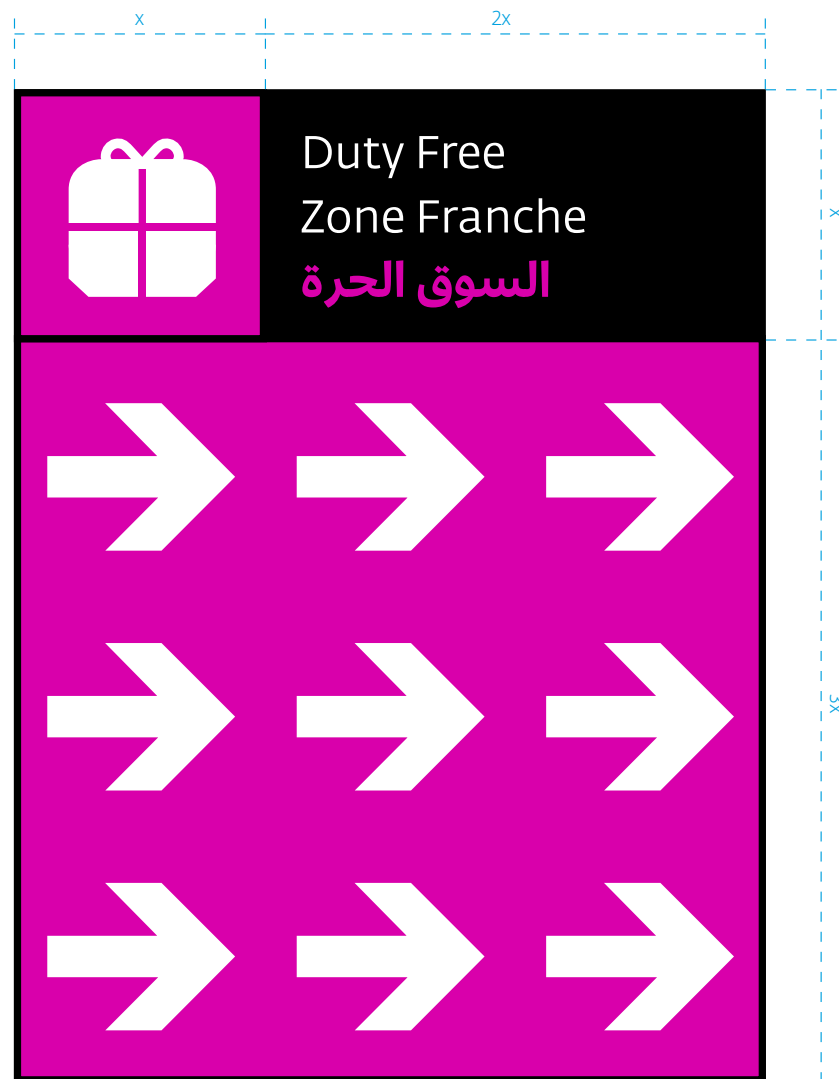



DIR. | ID. | INF. | REG.

IDENTIFICATION SIGNAGE

DIR. | ID. | INF. | REG.
Sign shape, plate & 3D adaptation

ID-Wrap is used when needed, serving as an identification sign wrapping around the structural poles. Poles are found everywhere in the Airport.

ID-Wrap
Wireframe front view

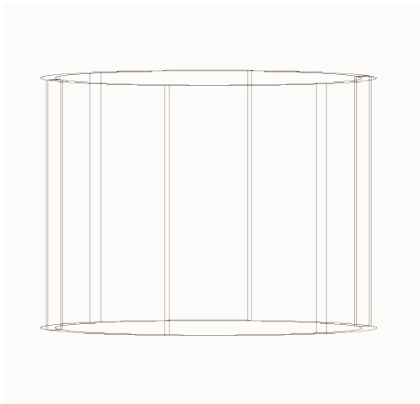

ID-Wrap
3D front view

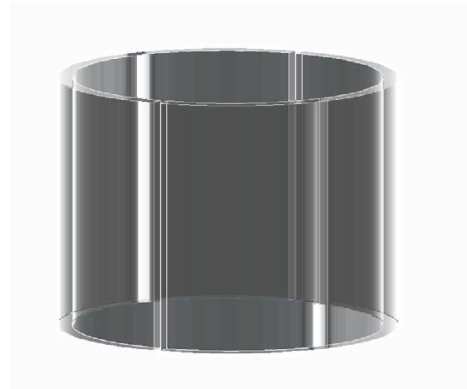

ID-Wrap
3D top view

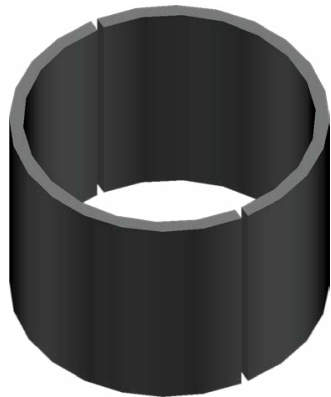

ID-Wrap
3D bottom view



DIR. | ID. | INF. | REG.
Sign shape, plate & 3D adaptation

To differentiate between the identification and the directional sign, the background colors switch (check below).

Black background
White pictogram

Colored background
Black message



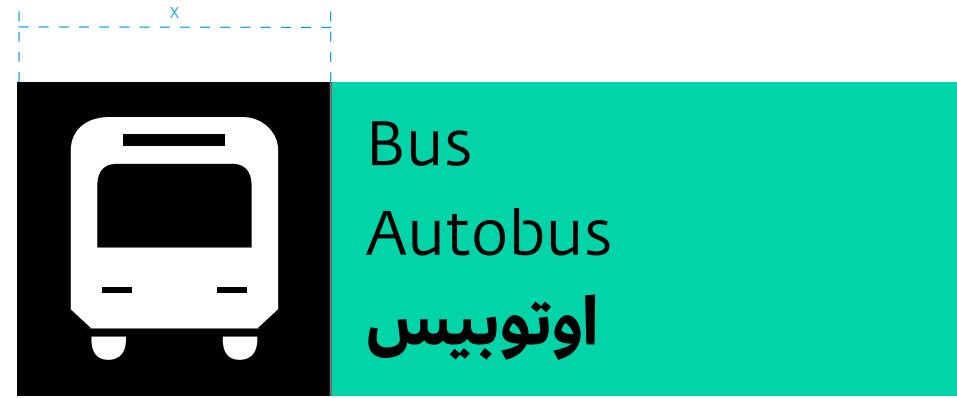
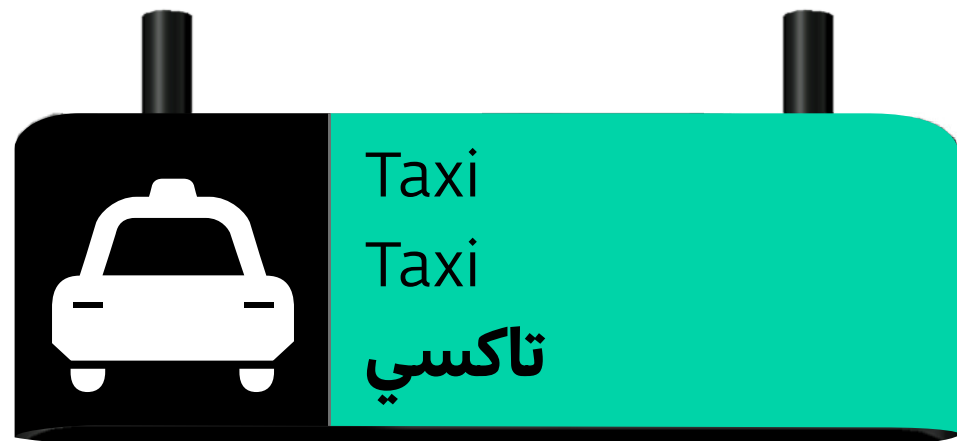

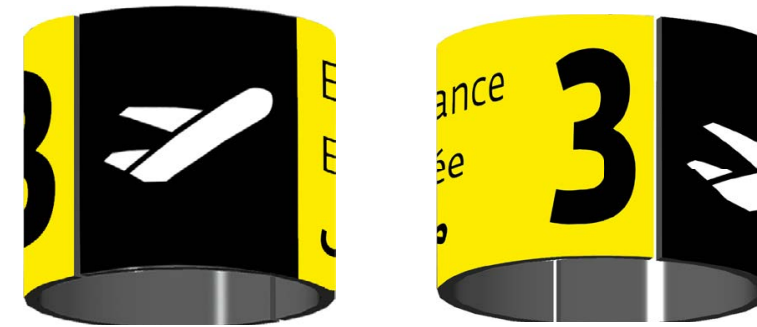



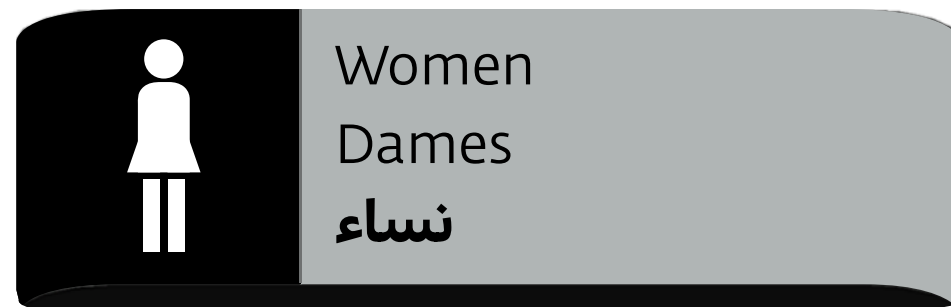

DIR. | ID. | INF. | REG.
Sign shape, plate & 3D adaptation



DIR. | ID. | INF. | REG.
Sign shape, plate & 3D adaptation



DIR. | ID. | INF. | REG.
Sign shape, plate & 3D adaptation



Digital L.E.D rotating information

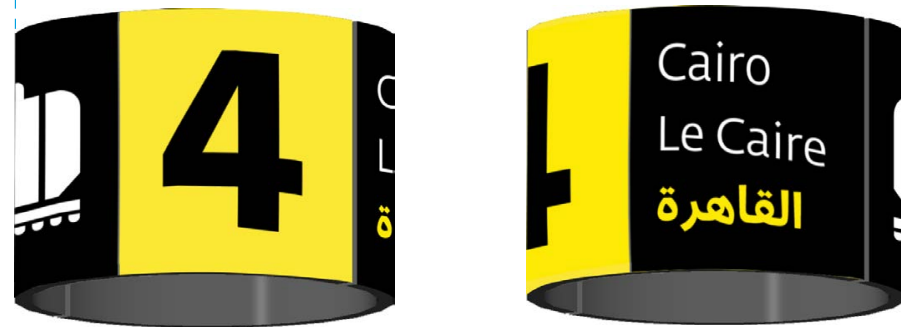

DIR. | ID. | INF. | REG.
Simulation





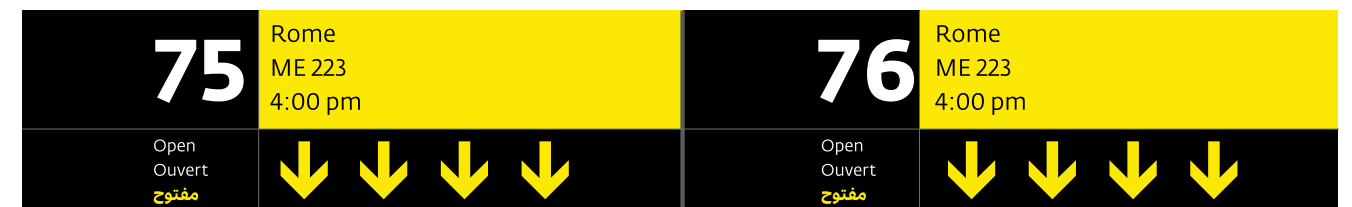
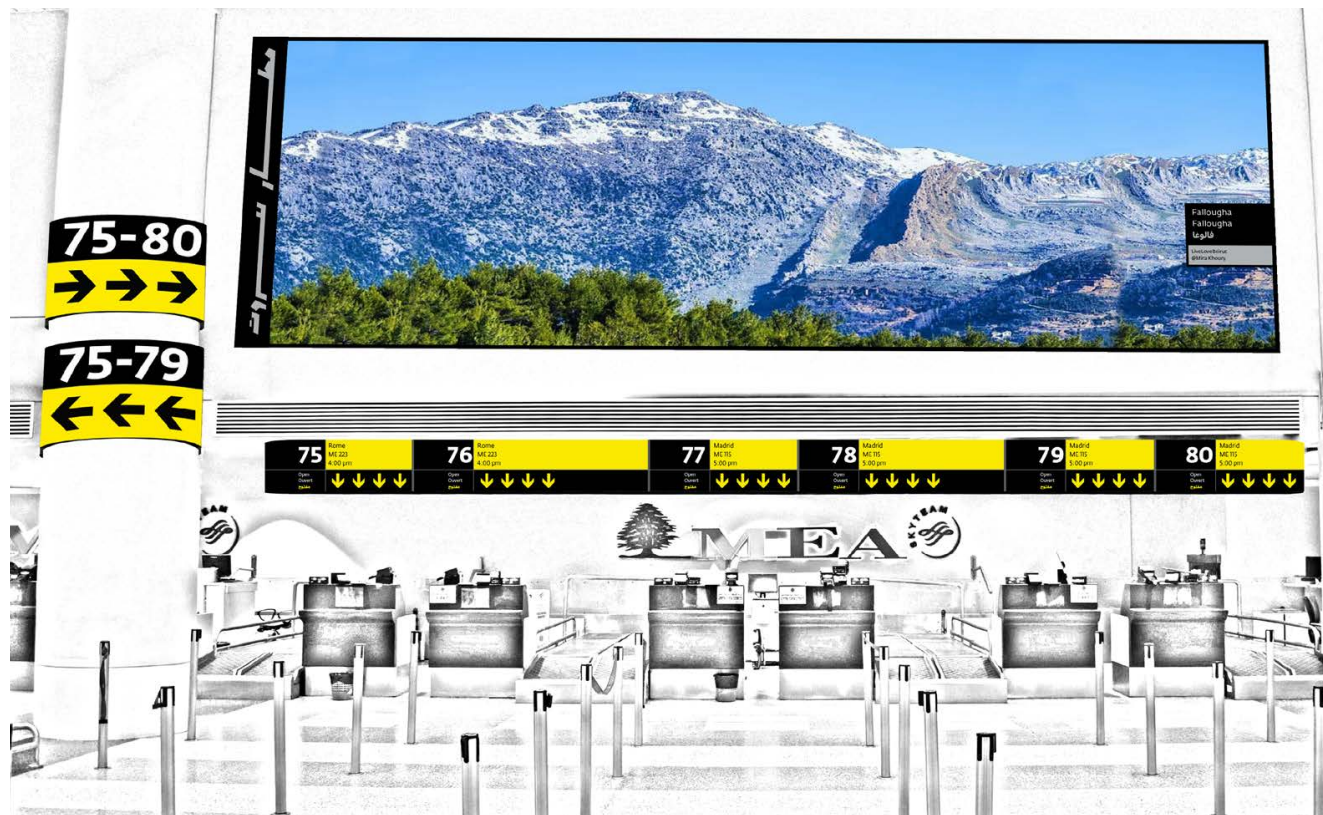

Digital L.E.D moving arrow

Digital L.E.D information



A self check-in space customized for the Airport. The machine is designed following the shape of the sign INF-Stand.

The cylindrical halo has a built in L.E.D yellow inner light that results in a light beam reflecting on the floor.



Photo example of color reflection



Proposed design scenario [departure]



Proposed design scenario [departure]

DIR. | ID. | **INF.** | REG.

INFORMATIONAL SIGNAGE

INF-Stand
Wireframe side view

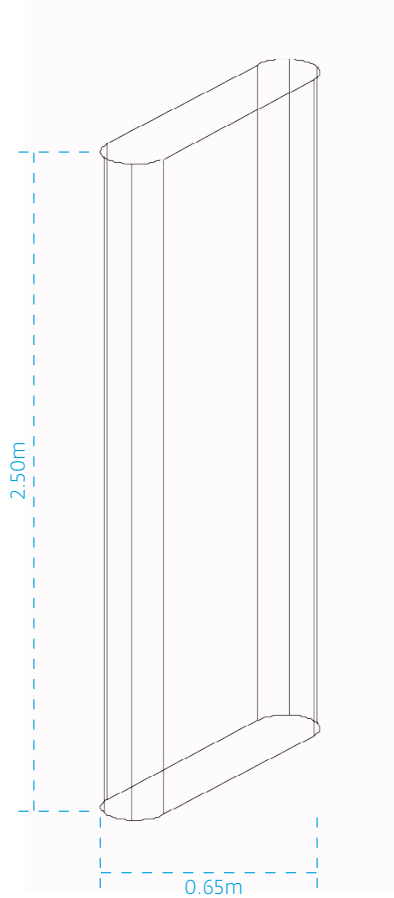

INF-Stand
3D top view

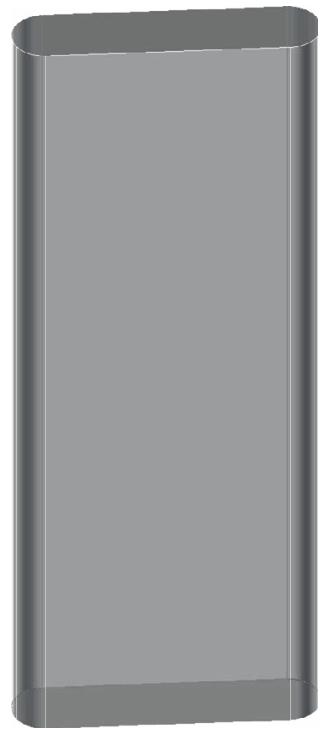

INF-Stand
3D front/side view

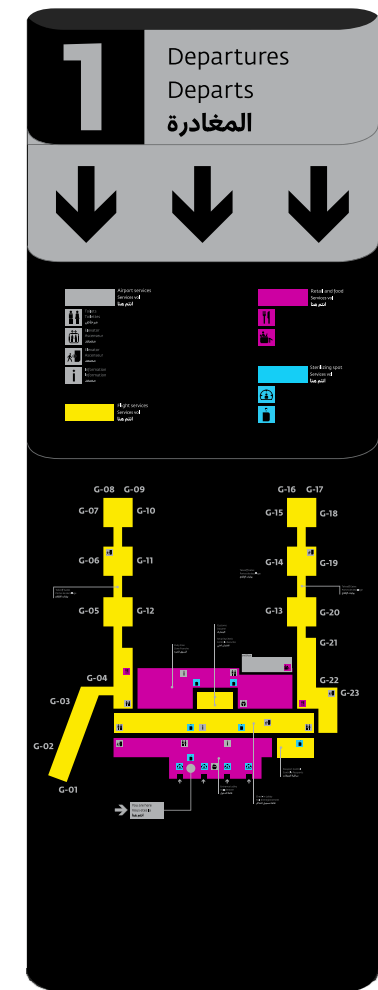
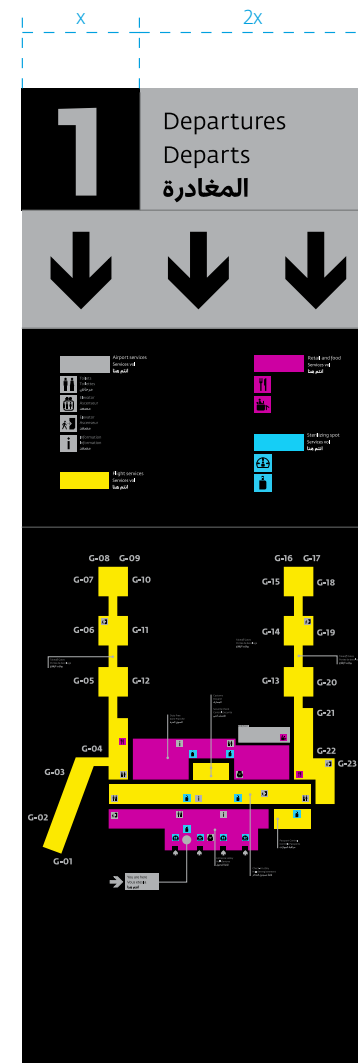
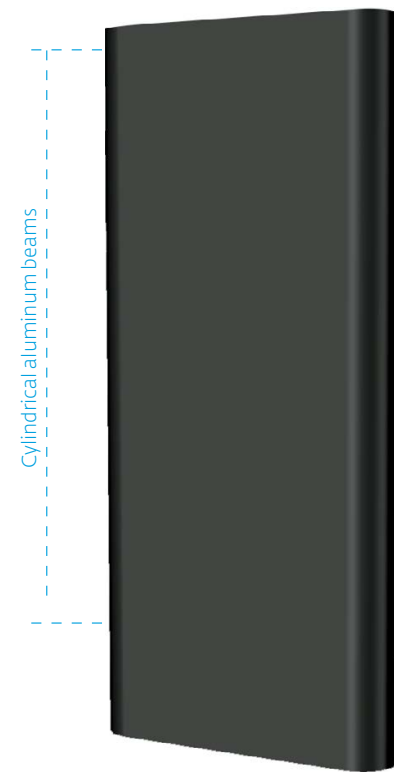

Customized and simplified plans for the Beirut International Airport, following the modular aspect of the signage system.

1st Floor, Departures

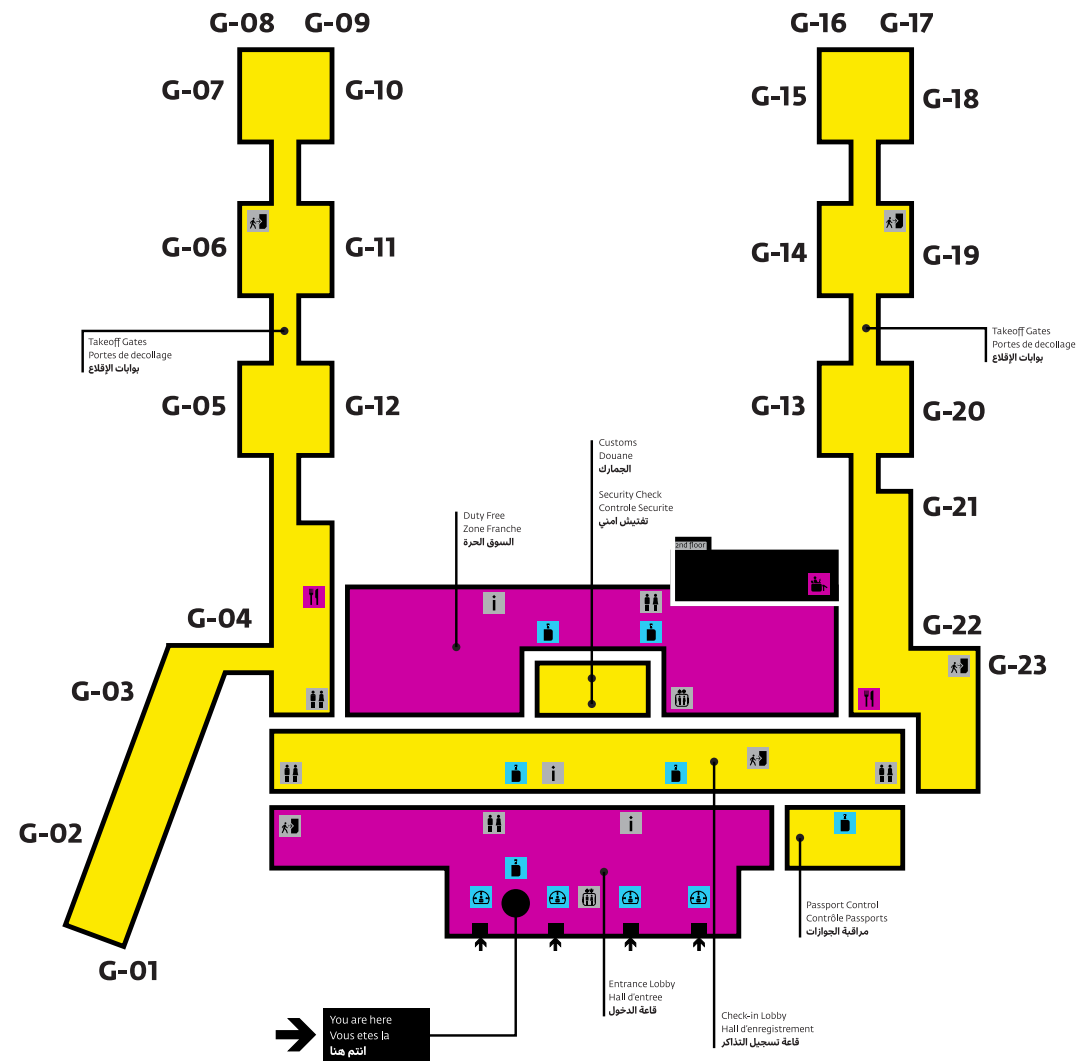

Ground Floor, Parking

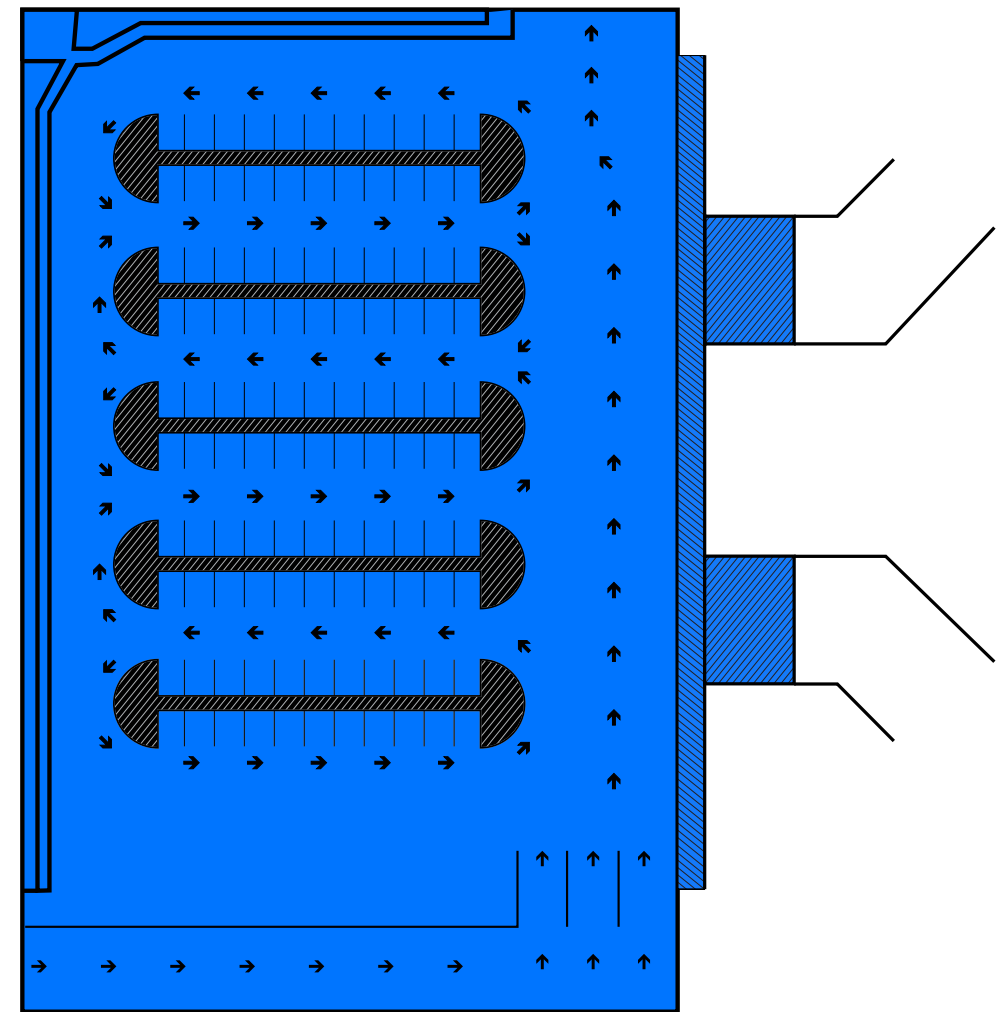

DIR. | ID. | INF. | REG.
Sign shape, plate & 3D adaptation

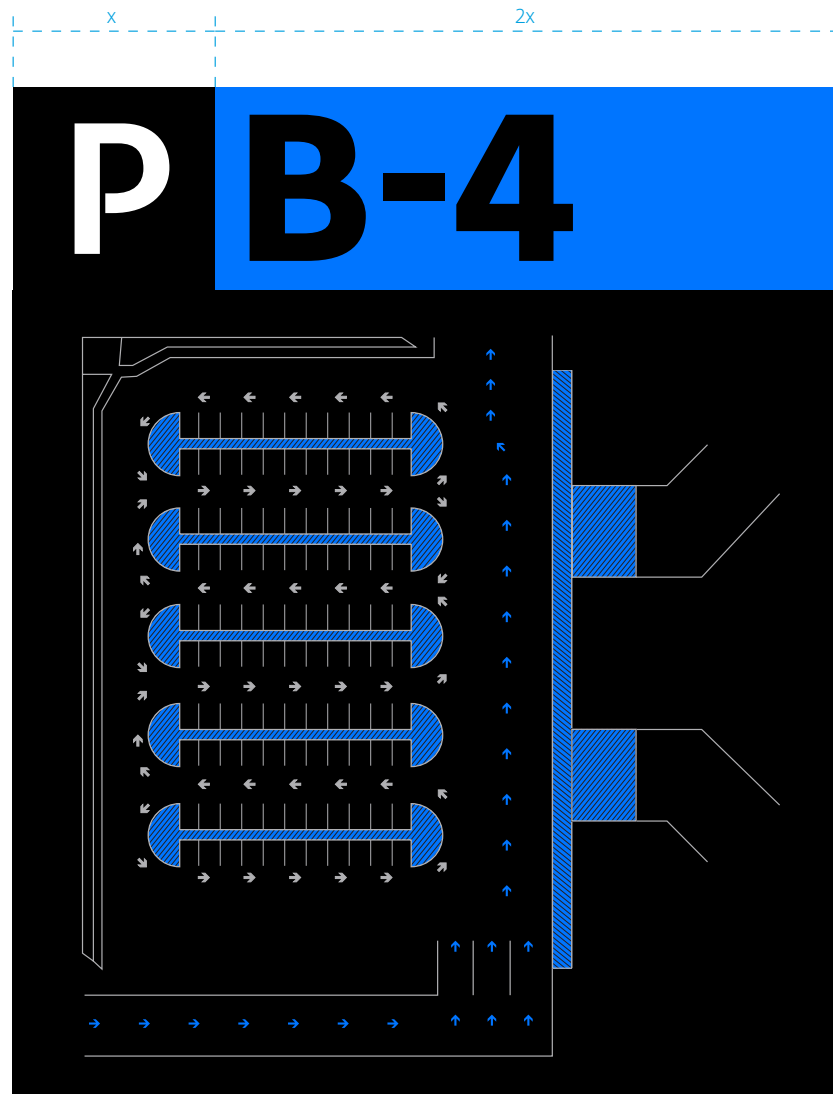

DIR. | ID. | INF. | REG.
Sign shape, plate & 3D adaptation

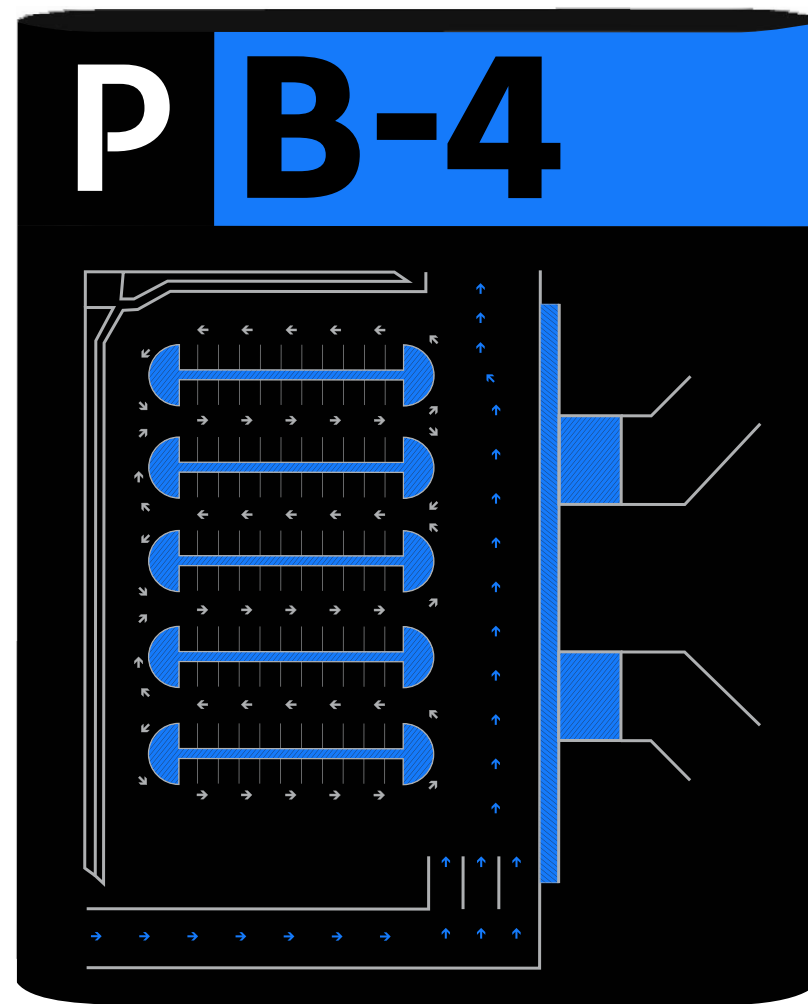

Placed at the beginning of
each driveway

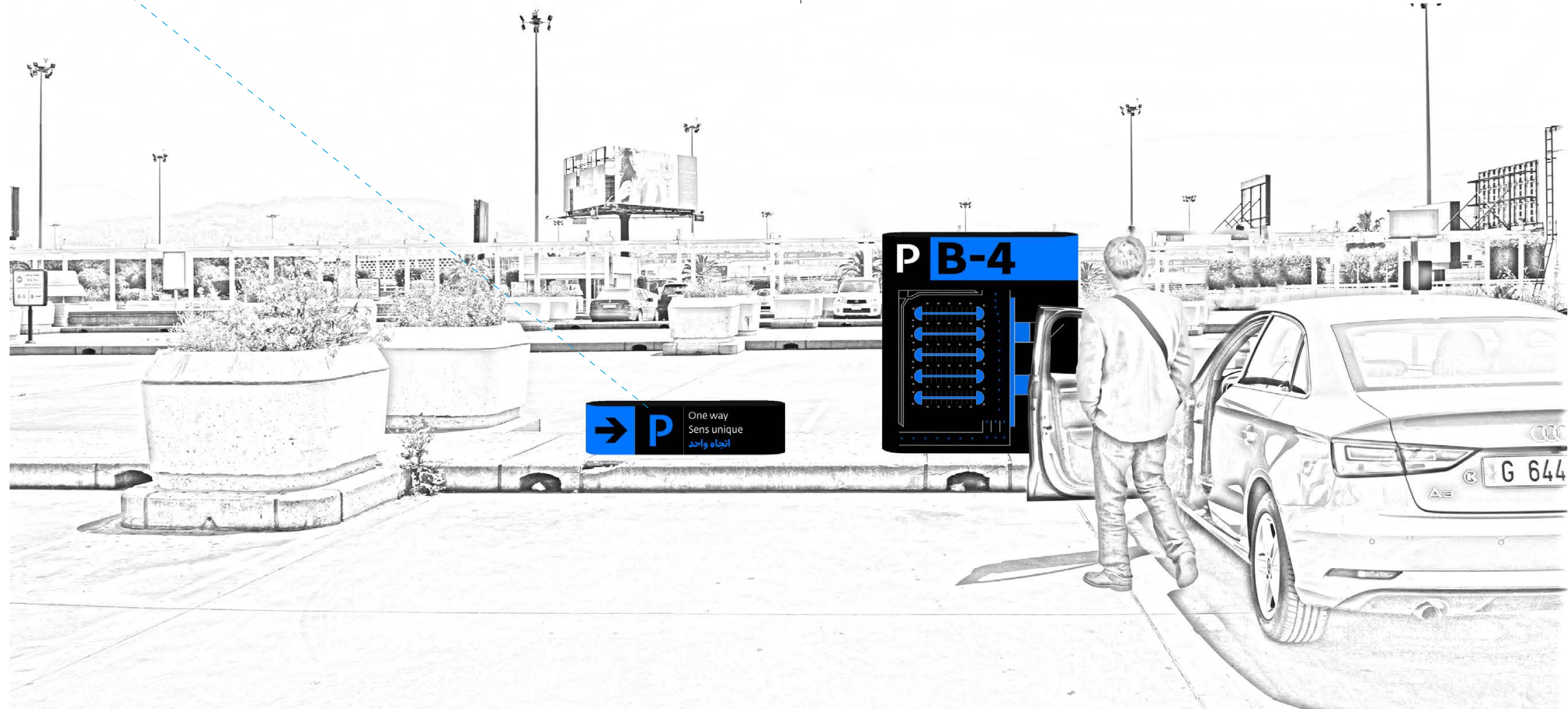

Customized flight board screens, wrapping around the existing structural poles in the Airport.

Digital L.E.D information

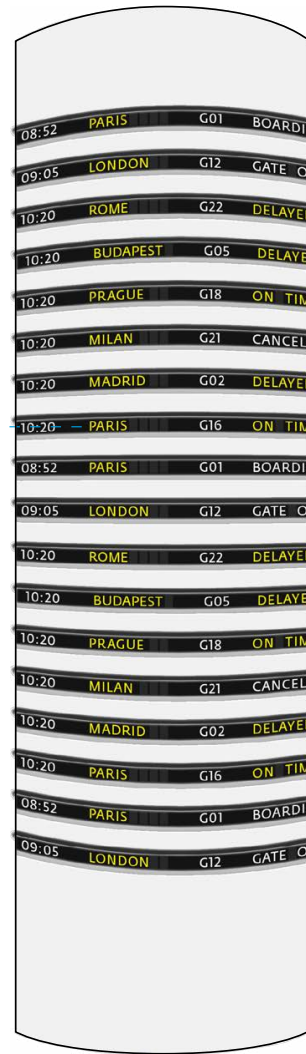

LiveLoveBeirut advertisements representing photographs of a Lebanese landscapes, found at several points in the Airport. Photographs are customized using the framing device below.

INF-Env.Graphics

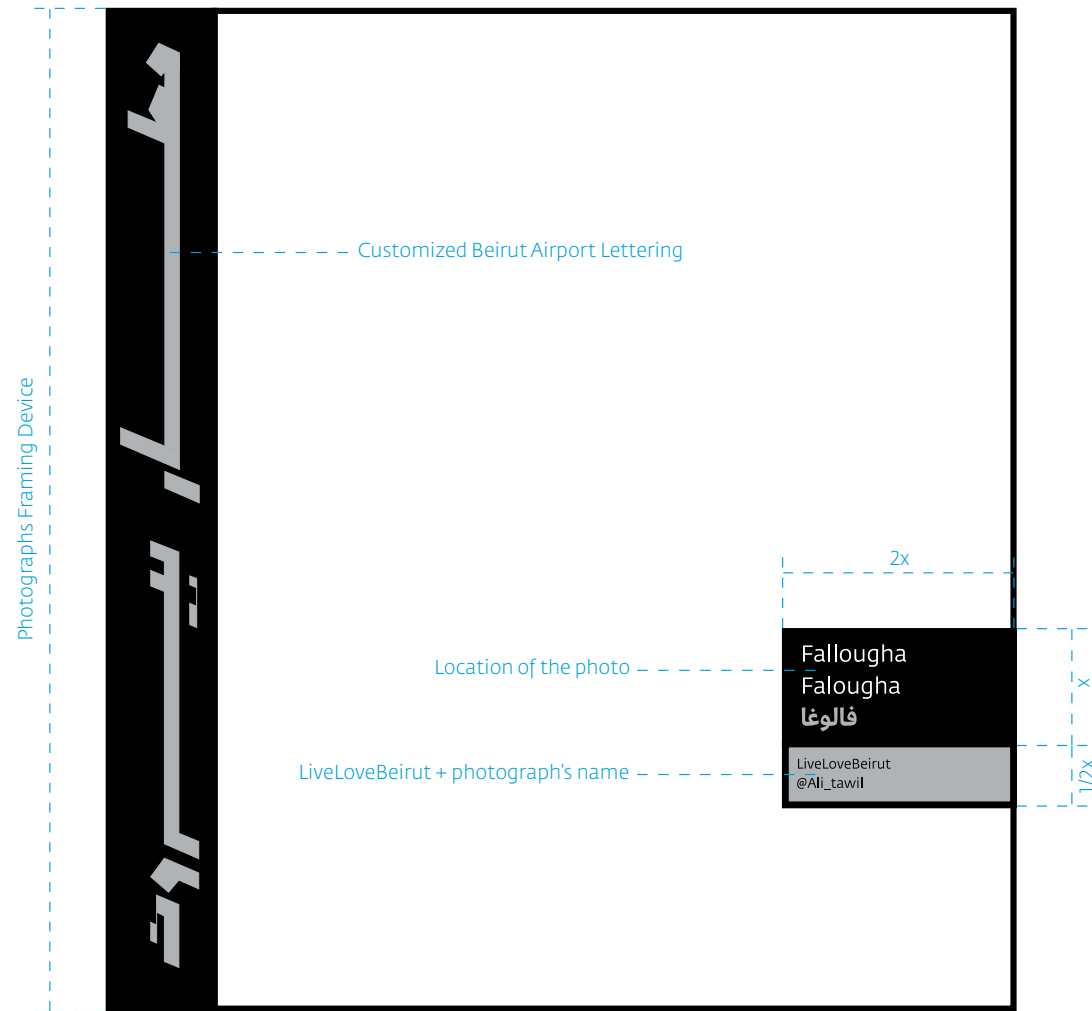





DIR. | ID. | INF. | **REG.**

REGULATORY SIGNAGE

DIR. | ID. | INF. | REG.
Sign shape, plate & 3D adaptation

ID/REG-Half and ID/REG-Mounted are mounted on doors or walls, when there is no poles.
The sign shape is used for regulatory signage.

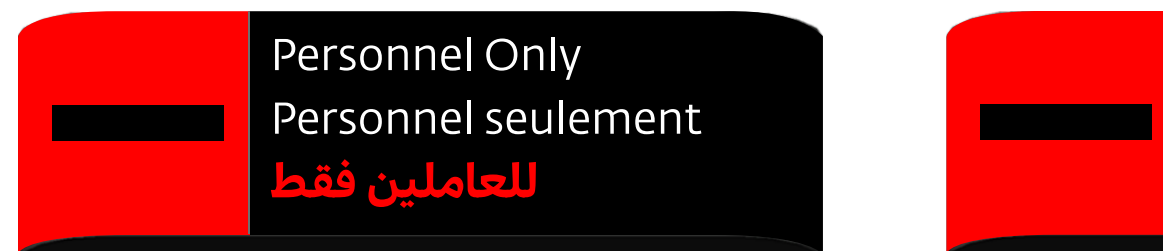
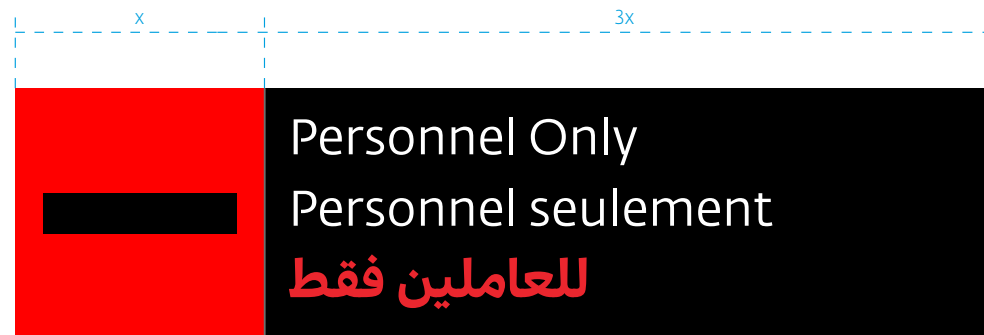

DIR. | ID. | INF. | REG.
Sign shape, plate & 3D adaptation

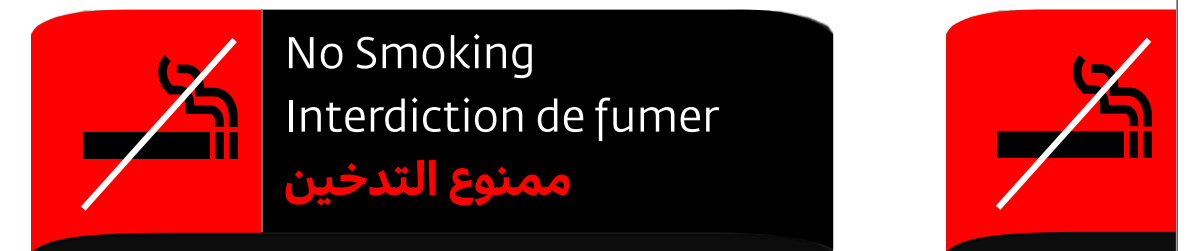

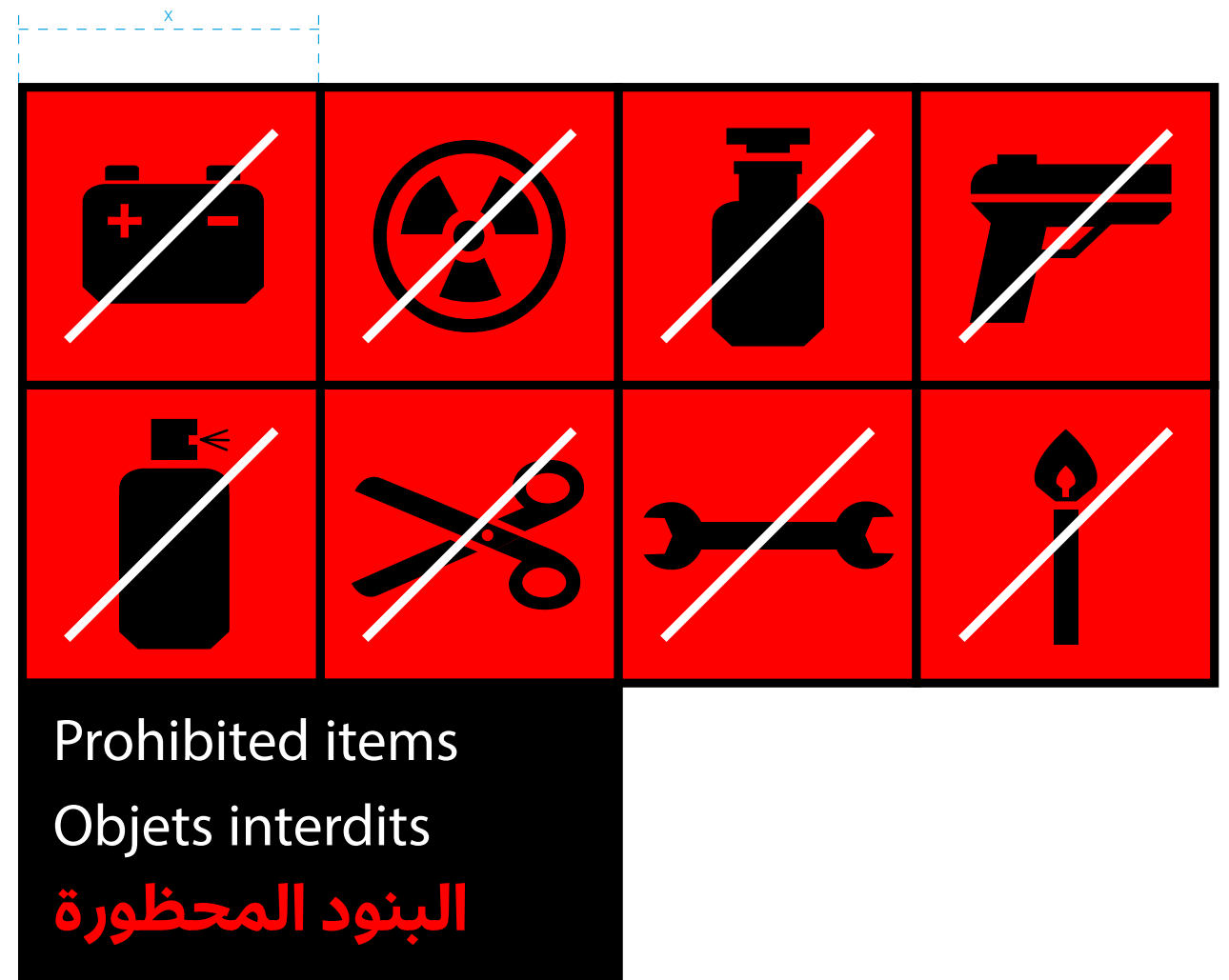
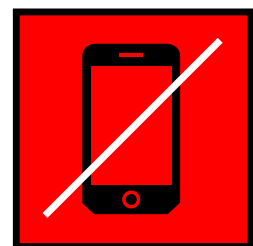

Have your liquids in a plastic bag
Déposez vos liquides dans un sac en plastique
قم بإزالة الأجهزة الإلكترونية

Empty your pockets
Videz vos poches
أفرغ جيوبك

Remove electronic devices
Retirez les appareils électroniques
قم بإزالة الأجهزة الإلكترونية



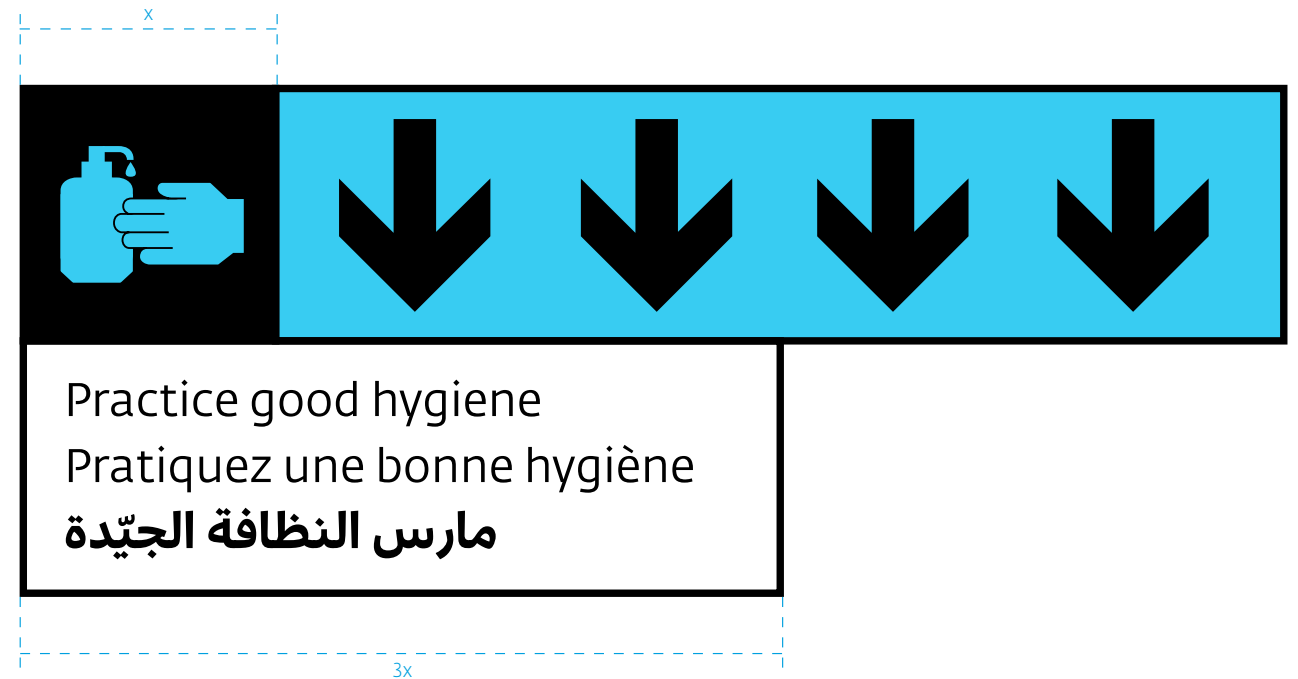

1. Covid-19 addition; customized sterilizing tunnel.
The system is based on the principle of using ionized saline solution (Anolyte) in the form of mist,

spraying the whole body to quickly disinfect the body surface.

Wireframe side view

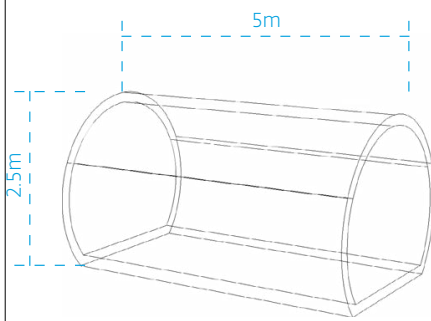

3D side/front view

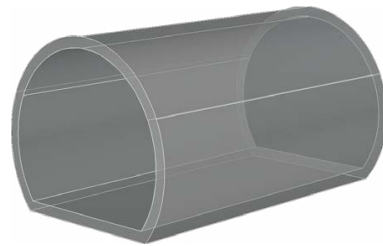

3D side/front view

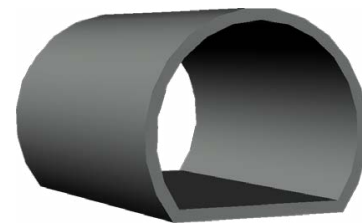

2. Covid-19 addition; Passport Disinfecting Device.
The device uses ultraviolet germicidal irradiation (UVGI) is a disinfection method that uses short-wavelength ultraviolet (UV-C) light to kill or inactivate microorganisms.

3D front view

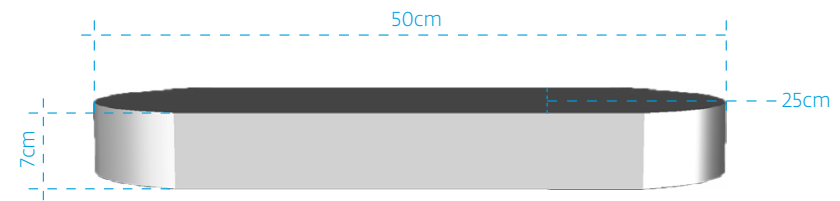

Wireframe top/side view

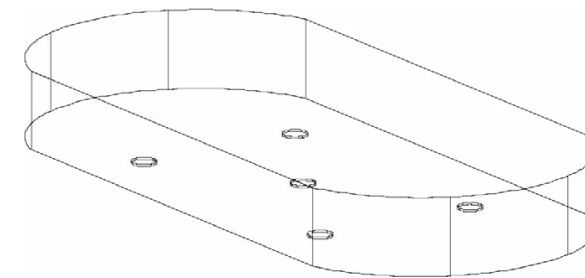

Wireframe bottom view

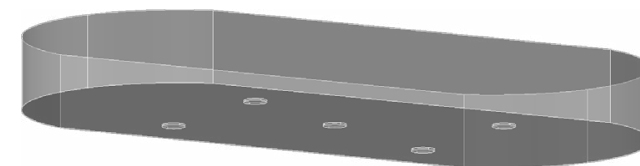



COVID-19 CUSTOMIZED FURNITURE

Covid-19 customized furniture

1. Covid-19 addition; customized seats design.
Each seat is a semi-cylinder module isolated from the other. Every person has his/her own space, isolated from others. No physical contact.

The seats are 1 meter far from each other.

3D front view

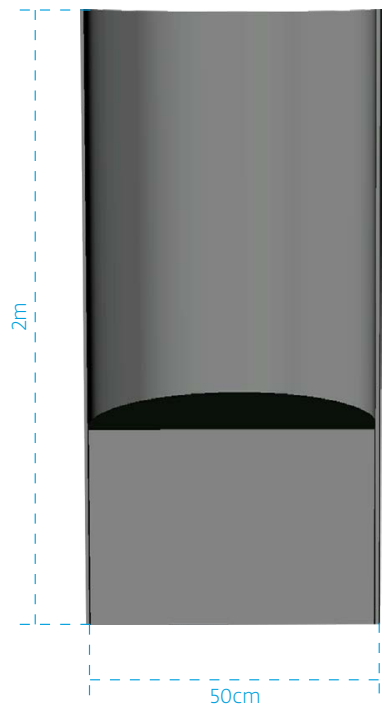

3D side view

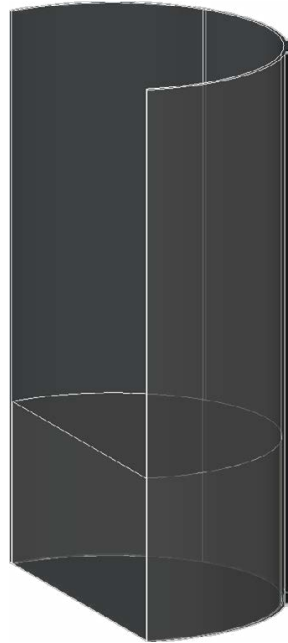

Wireframe back view

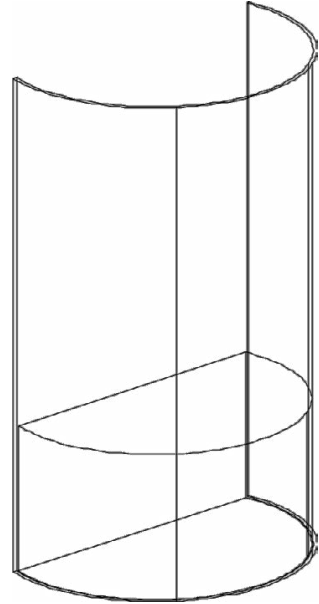

Covid-19 customized furniture

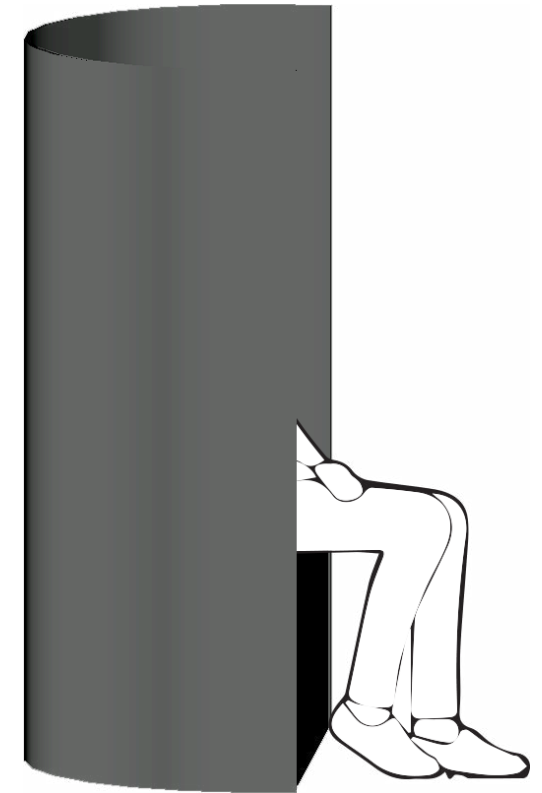

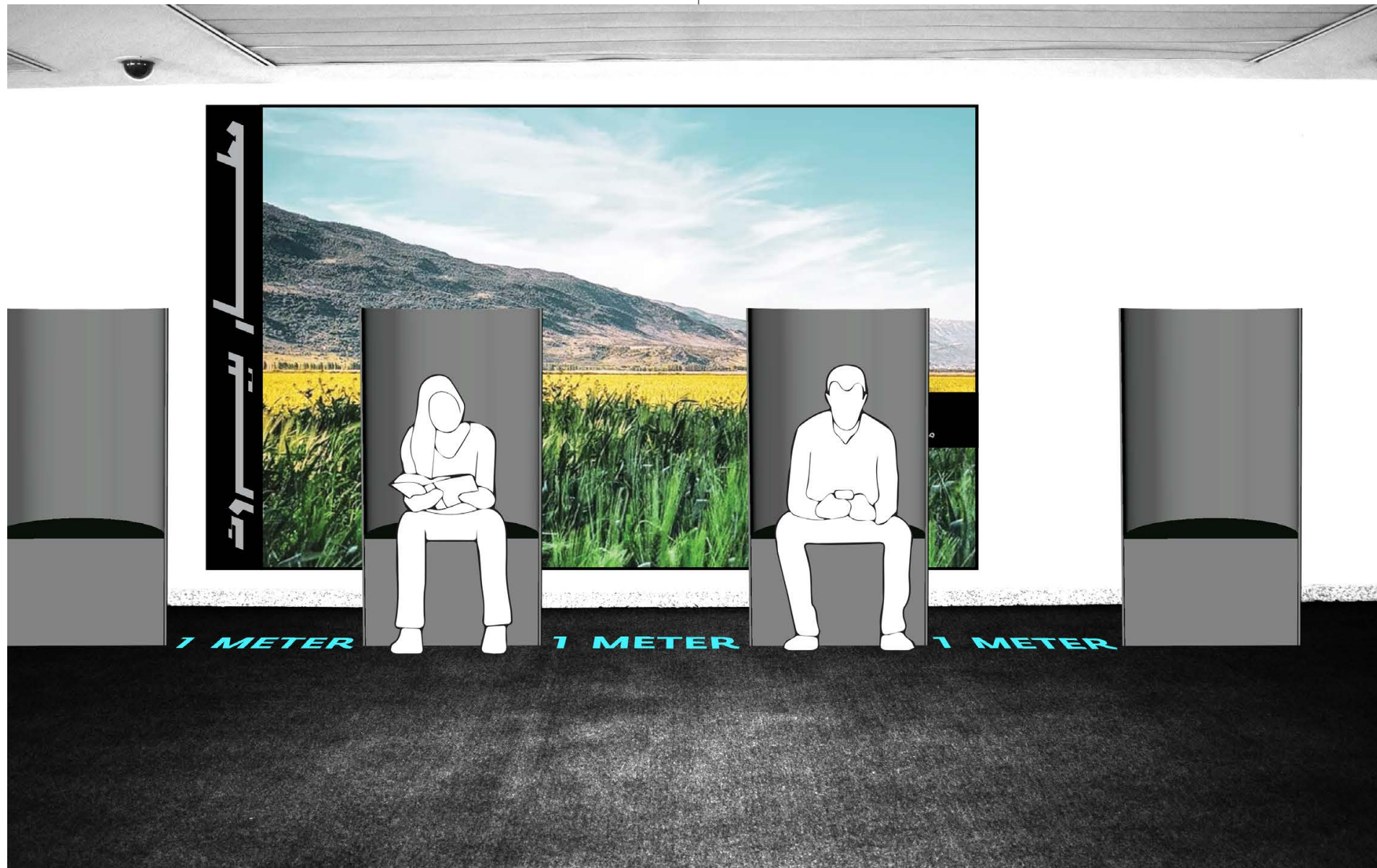

Family shot

FAMILY SHOT

Family shot

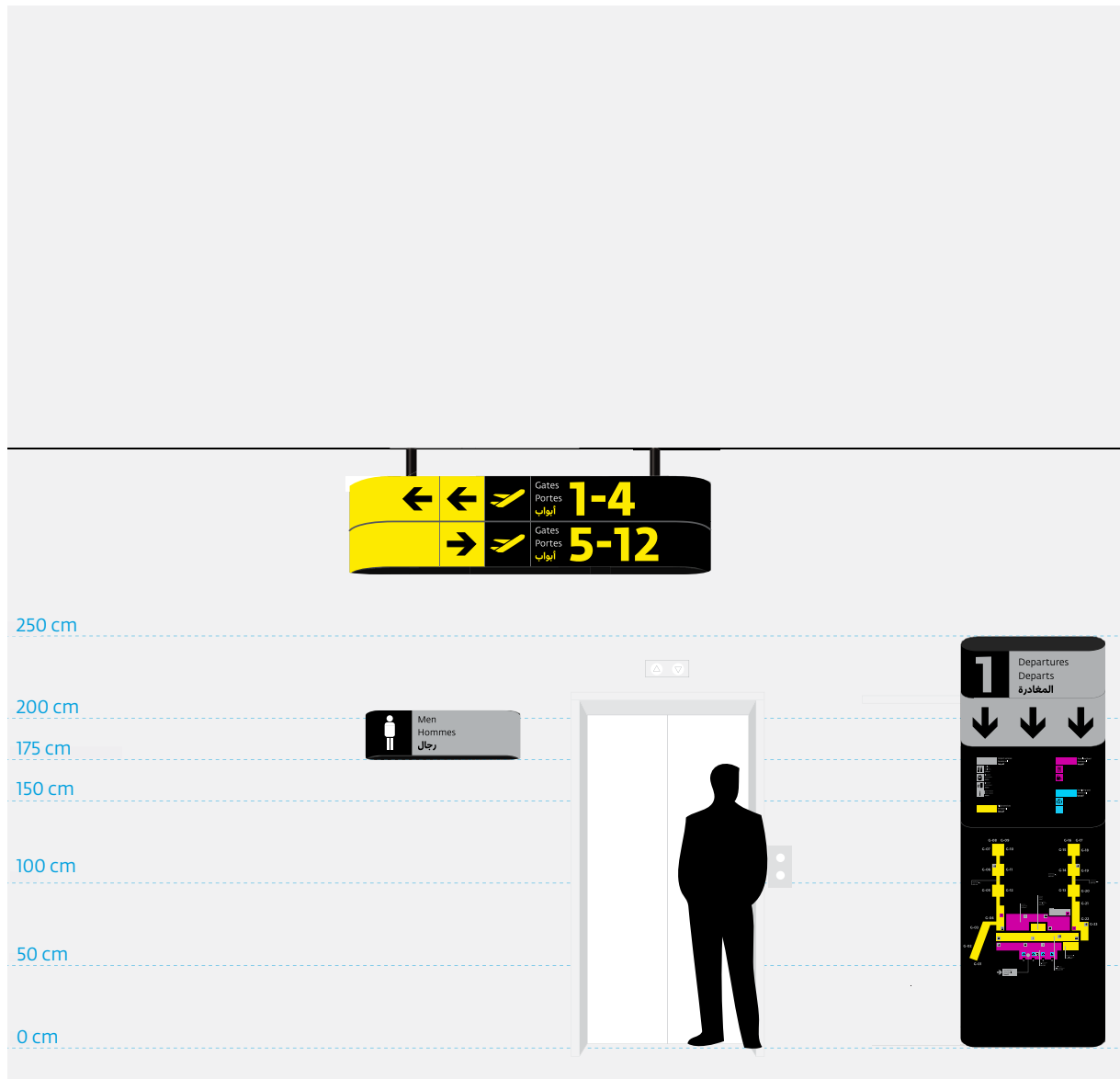

250 cm
 200 cm
 175 cm
 150 cm
 100 cm
 50 cm
 0 cm

Family shot

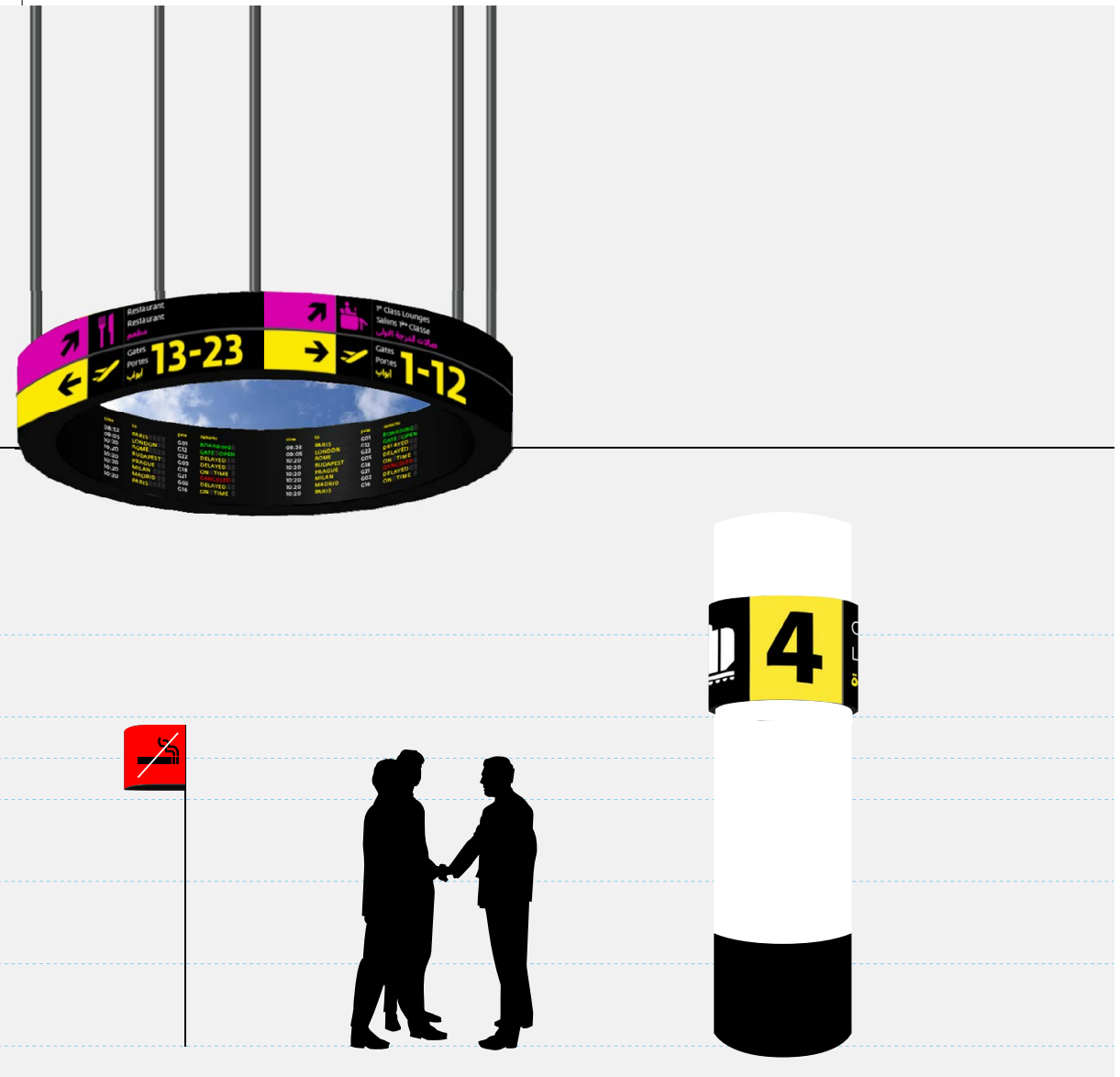

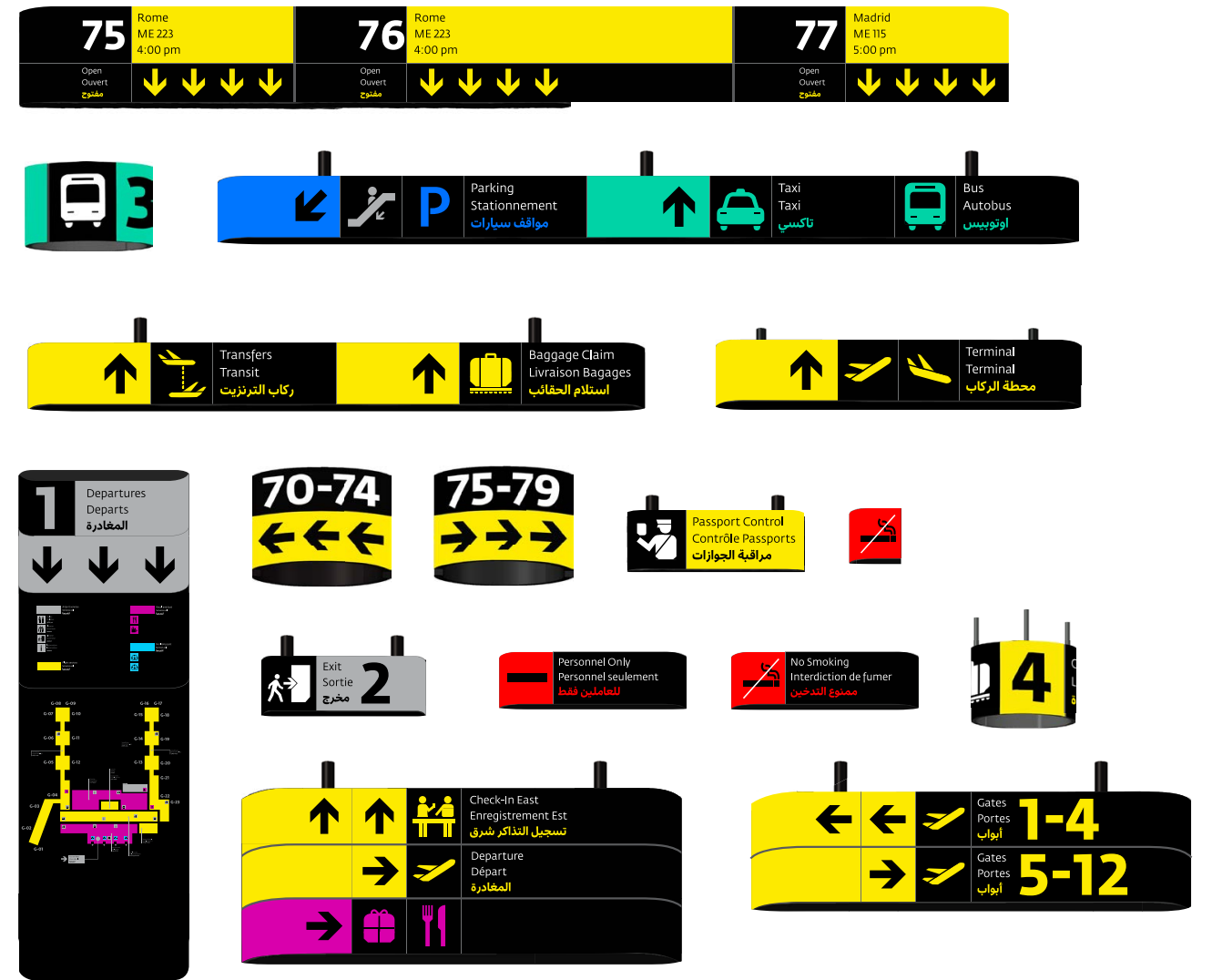
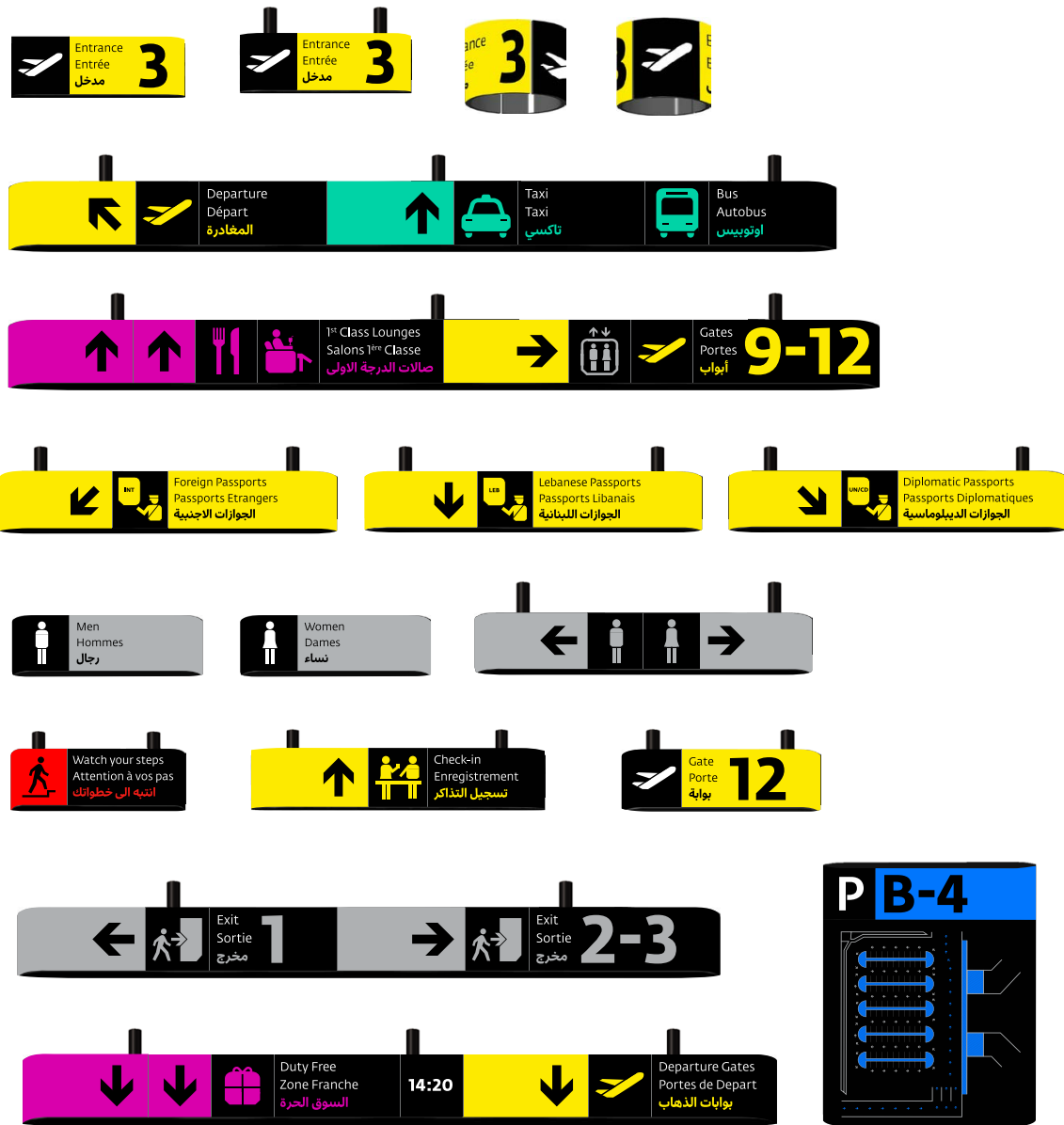

VI- USER SCENARIOS

CURRENT STATE SCENARIO [DEPARTURE]

Current state scenario [departure]

Below represents the current state scenario of the Beirut Rafic Hariri International Airport along with the signs seen throughout. A persona is created, following a specific scenario.

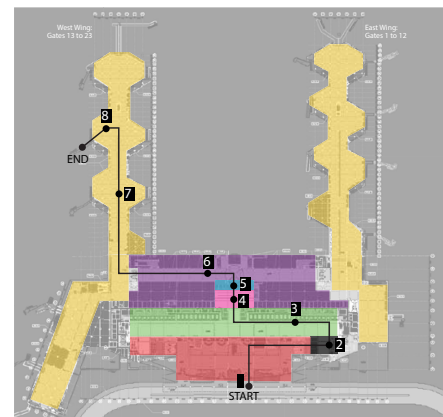

1st FLOOR | DEPARTURE

- Entrance Hall
 - Passport Control
 - Check in
 - Security Control
 - Customs
 - Duty Free
 - Gates
- 1 Gate #12
2 Toilet
3 Cedar Lounge
4 Passport Control
5 Security Control
6 Check-in
7 Passport Control
8 Dropped on Entrance #2 + Luggage Cart



Leila is a 25 years old woman making her way to the airport, leaving Beirut. She goes through all the procedures, in order to reach her Gate.

* Missing Sign

- SIGN TYPE
- Informational Sign
 - Regulatory Sign
 - Directional Sign
 - Identification Sign

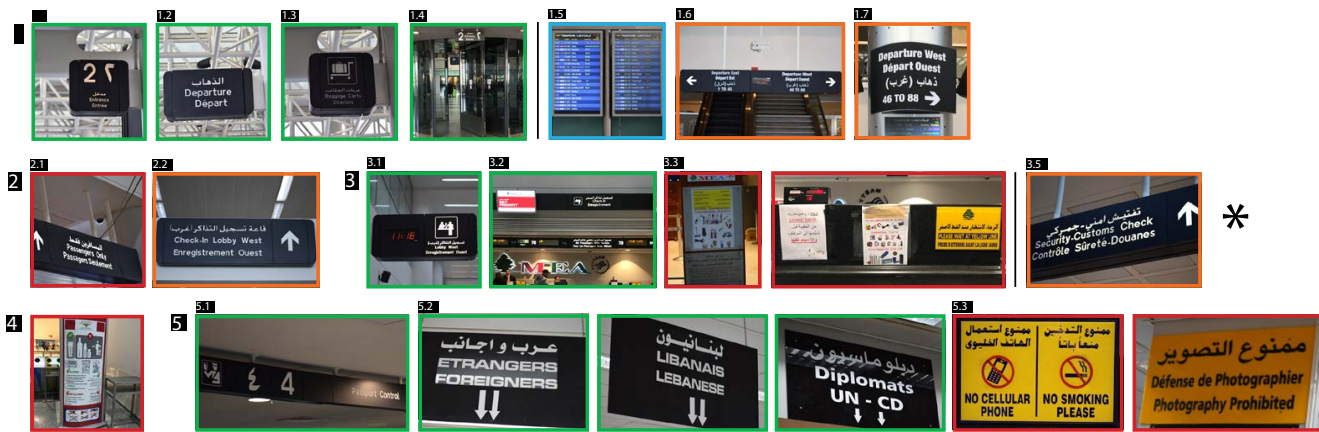

Current state scenario [departure]



PROPOSED DESIGN SCENARIO [DEPARTURE]

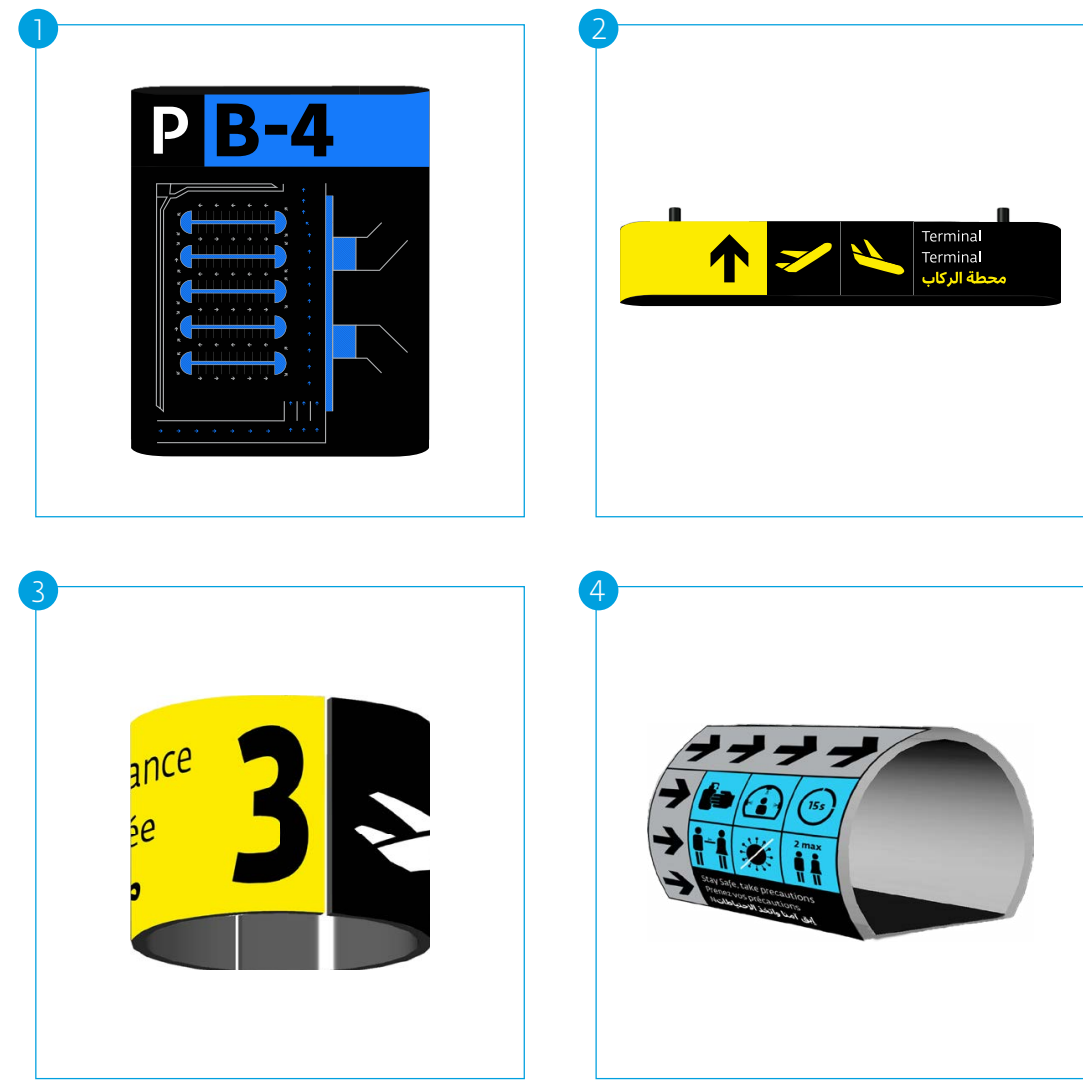
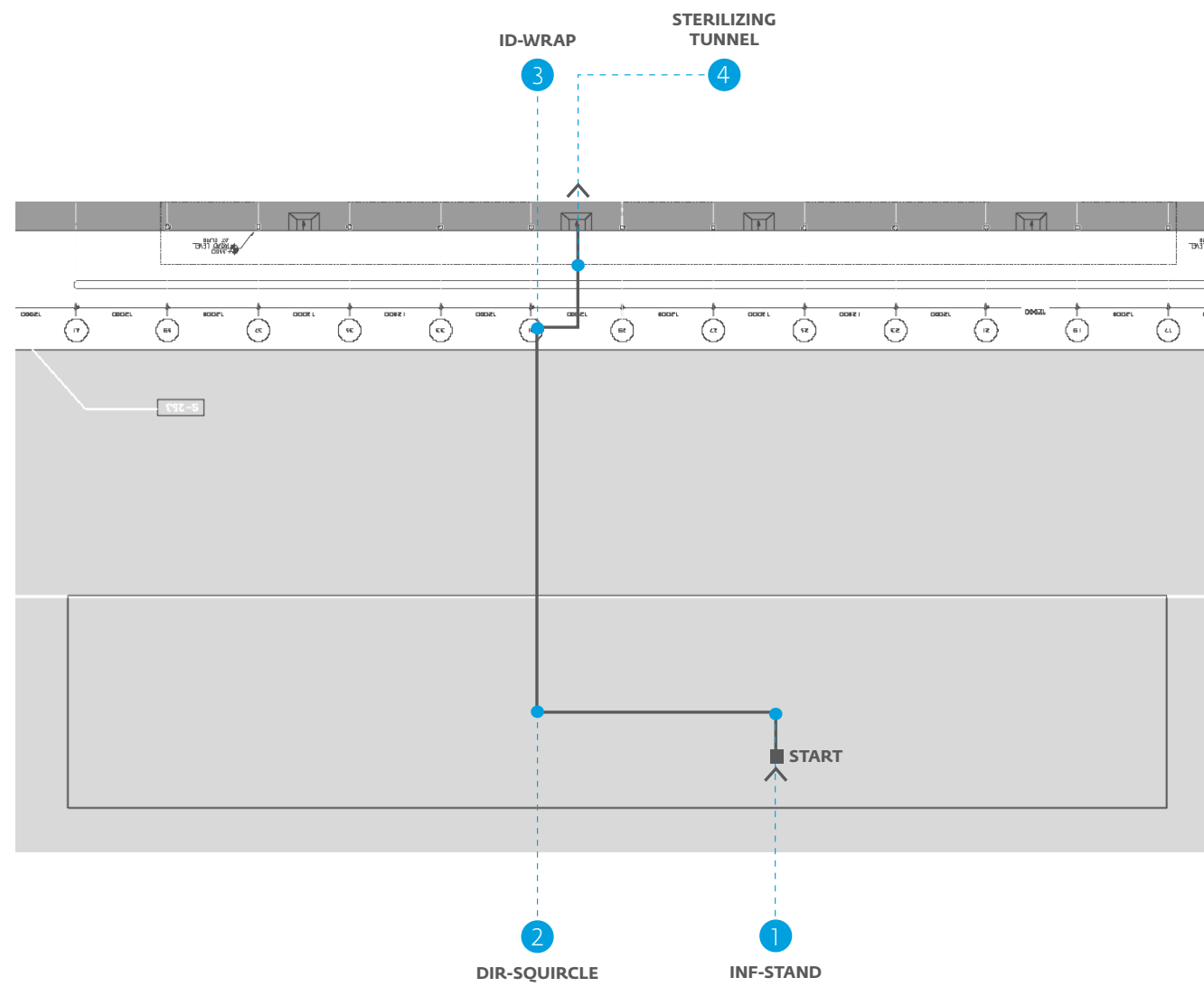

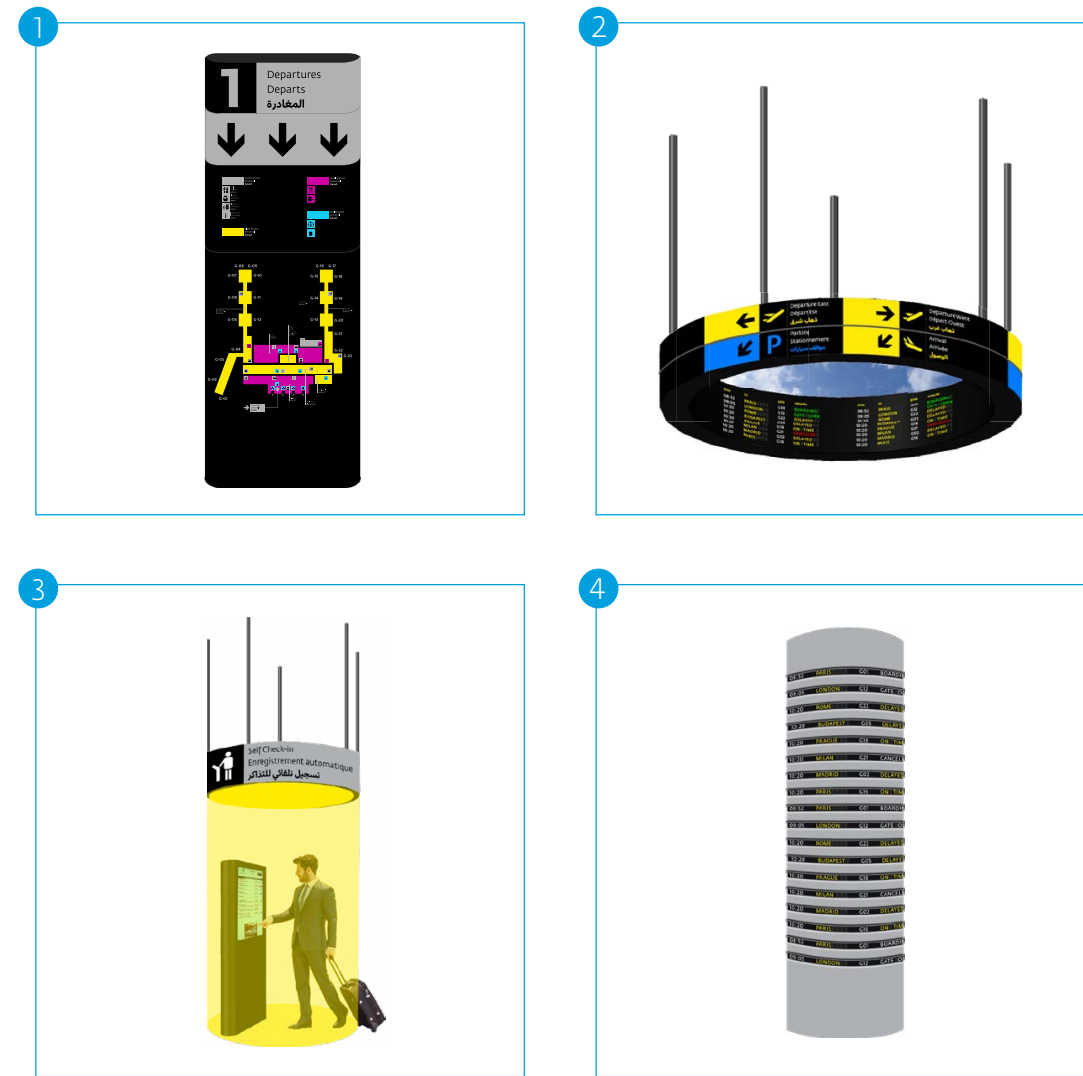
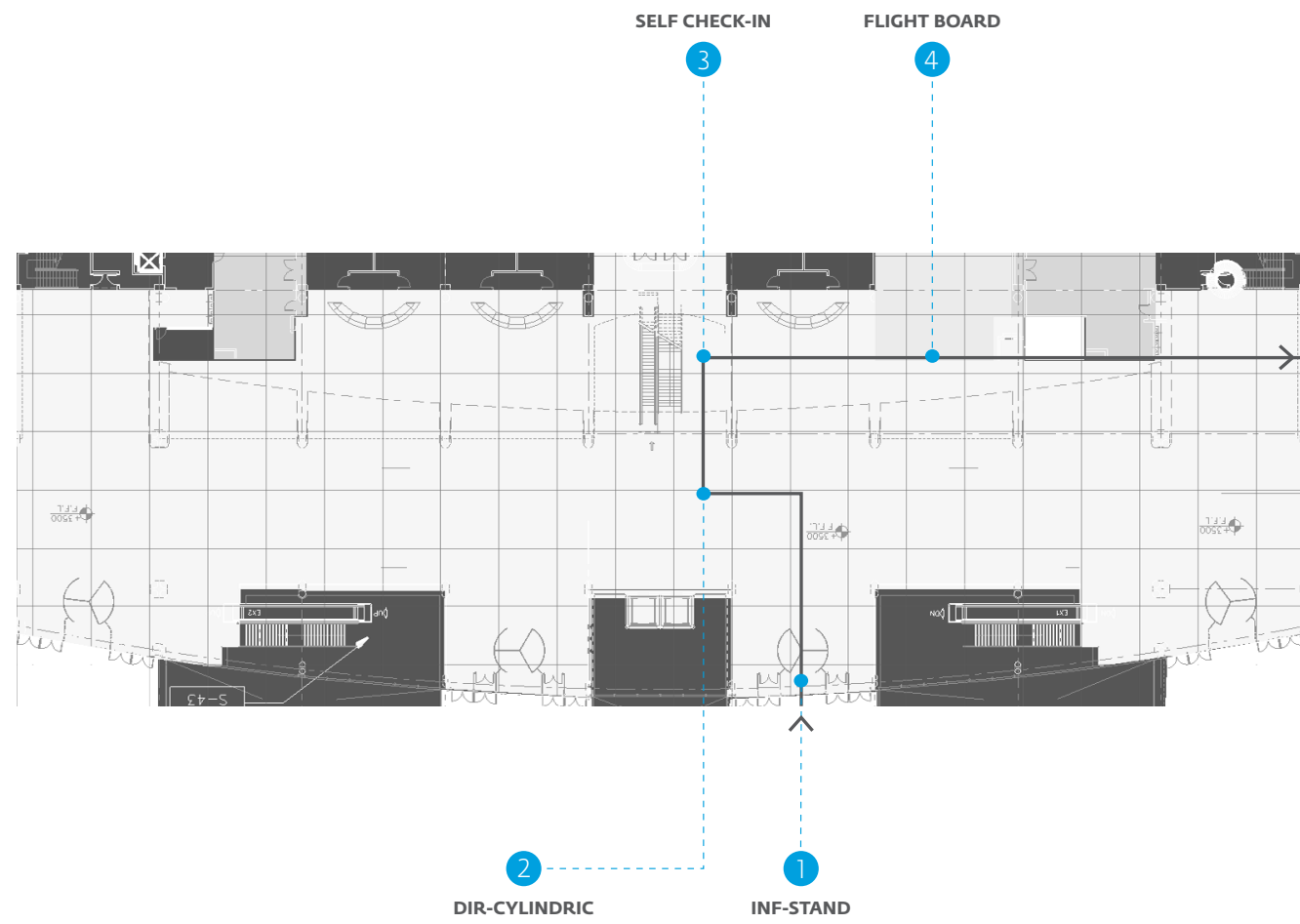

Proposed design scenario [departure]
PASSPORT CONTROL

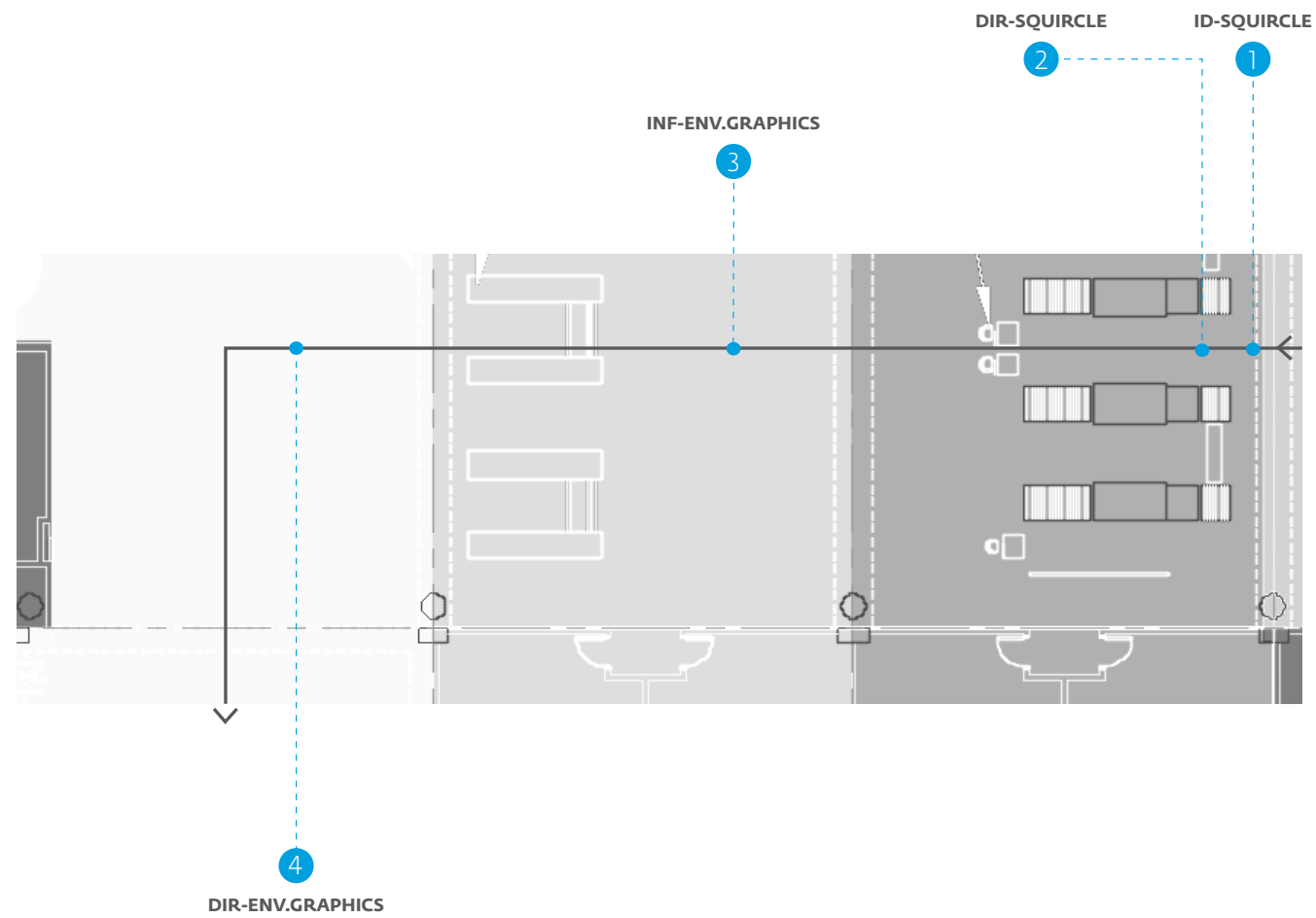

Proposed design scenario [departure]
PASSPORT CONTROL



Proposed design scenario [departure]
CHECK-IN LOBBY

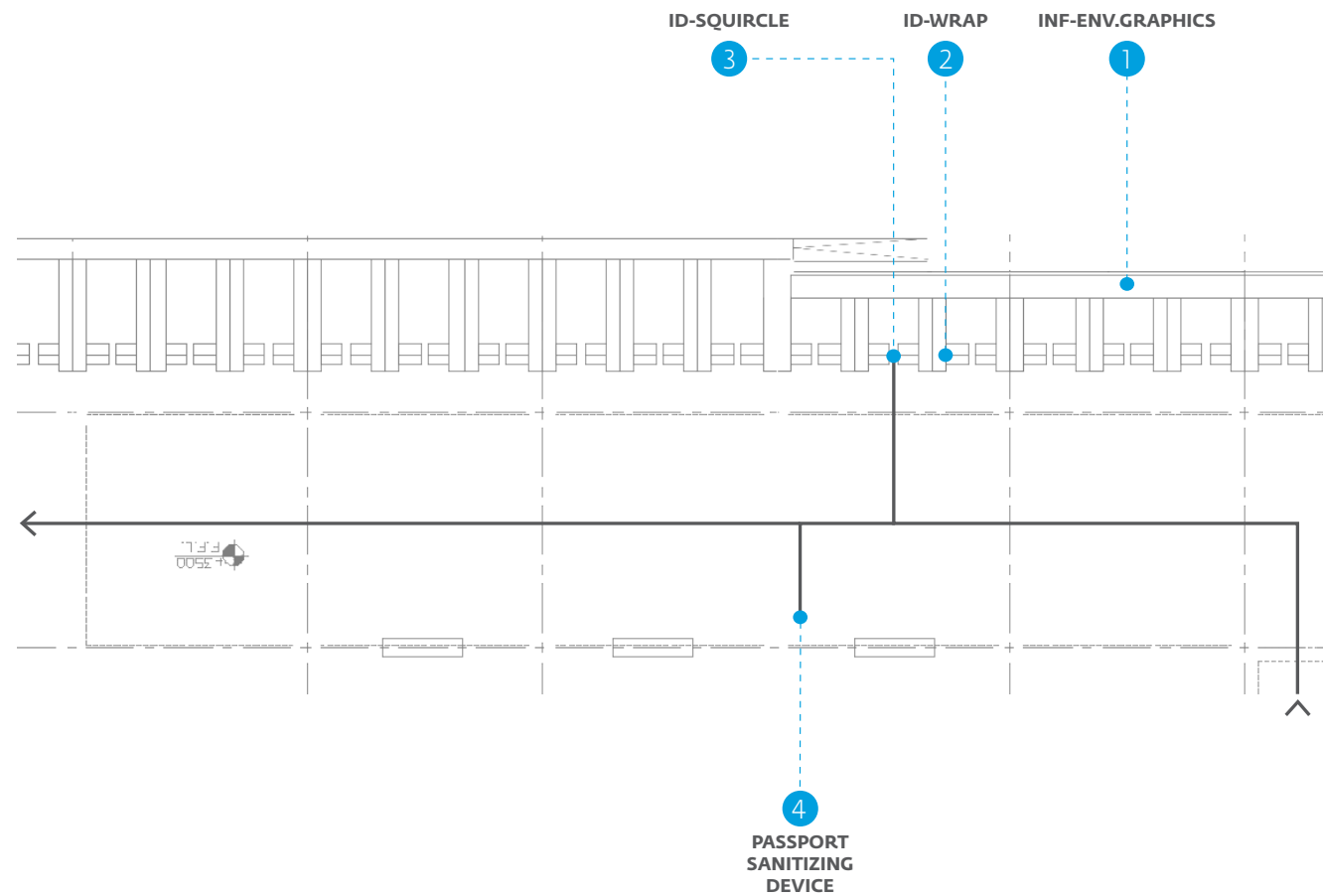

Proposed design scenario [departure]
CHECK-IN LOBBY

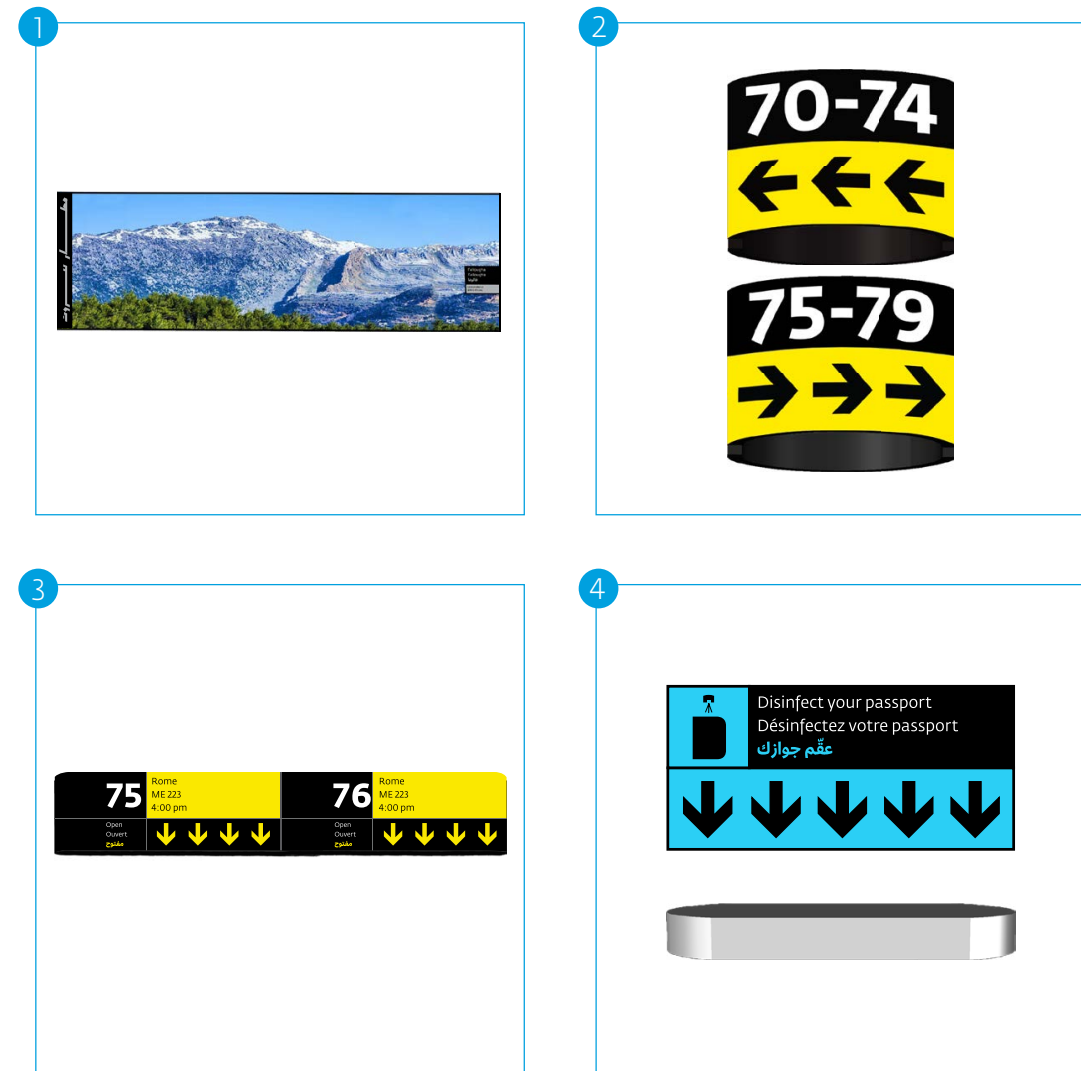

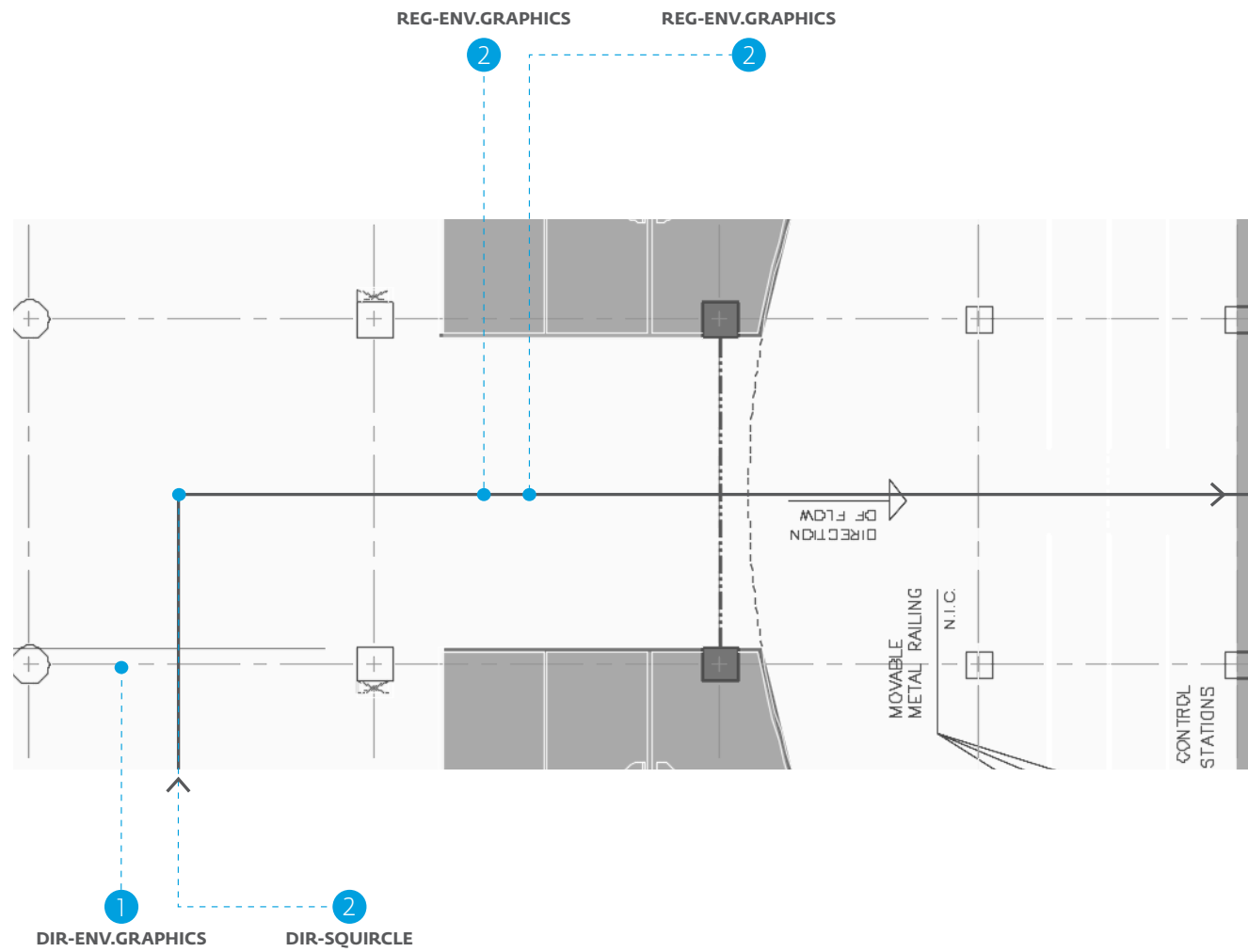

1

Security Check
Contrôle Sûreté
تفتيش أمني

2

Check-In East
Enregistrement Est
تسجيل النفاذ شرقي
Departure
Départ
المغادرة

3

Prohibited items
Objets interdits
البضود المحظورة

4

Have your liquids in a plastic bag
Déposez vos liquides dans un sac en plastique
قم بإزالة الأجهزة الإلكترونية
Empty your pockets
Videz vos poches
أفرغ جيوبك
Remove electronic devices
Retirez les appareils électroniques
قم بإزالة الأجهزة الإلكترونية

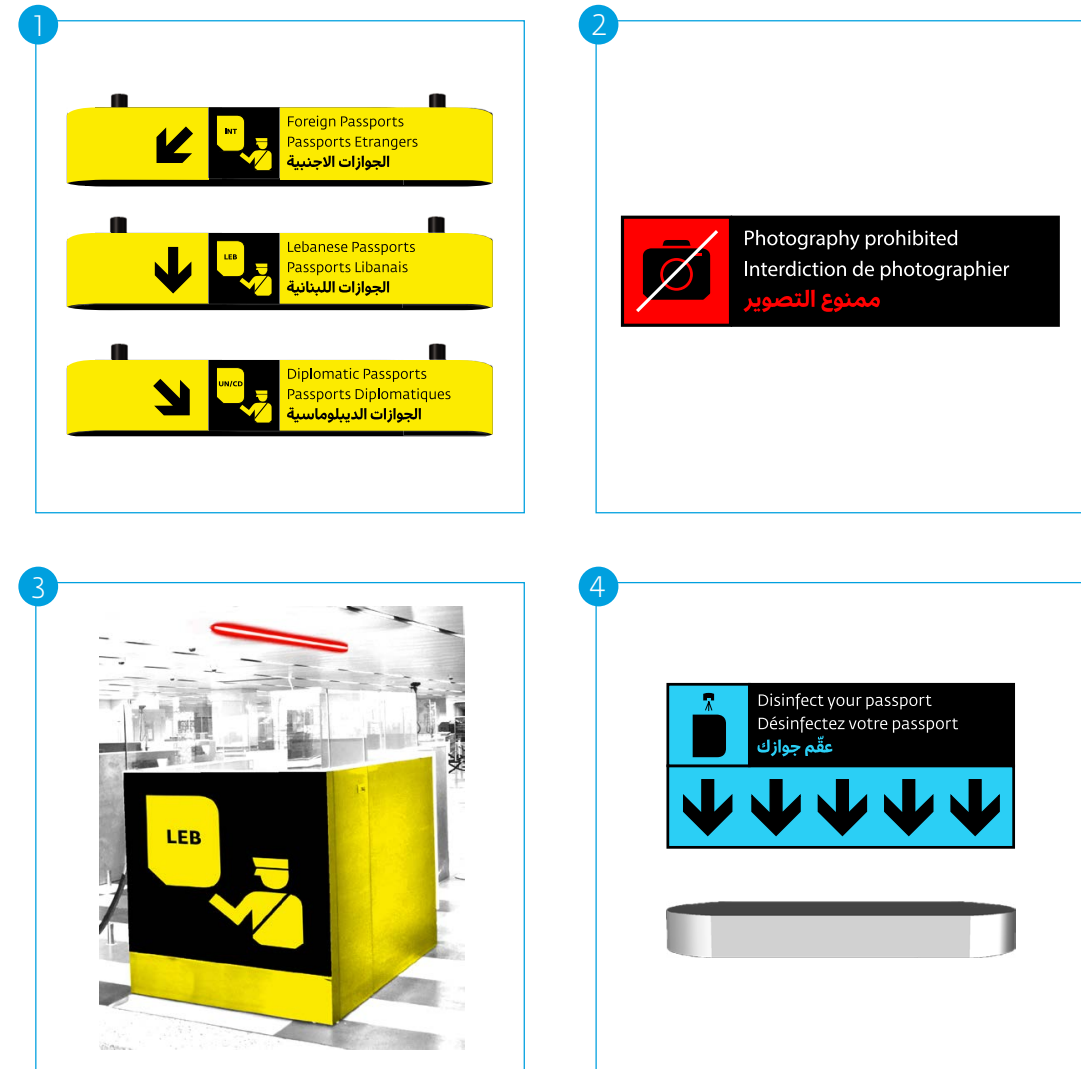
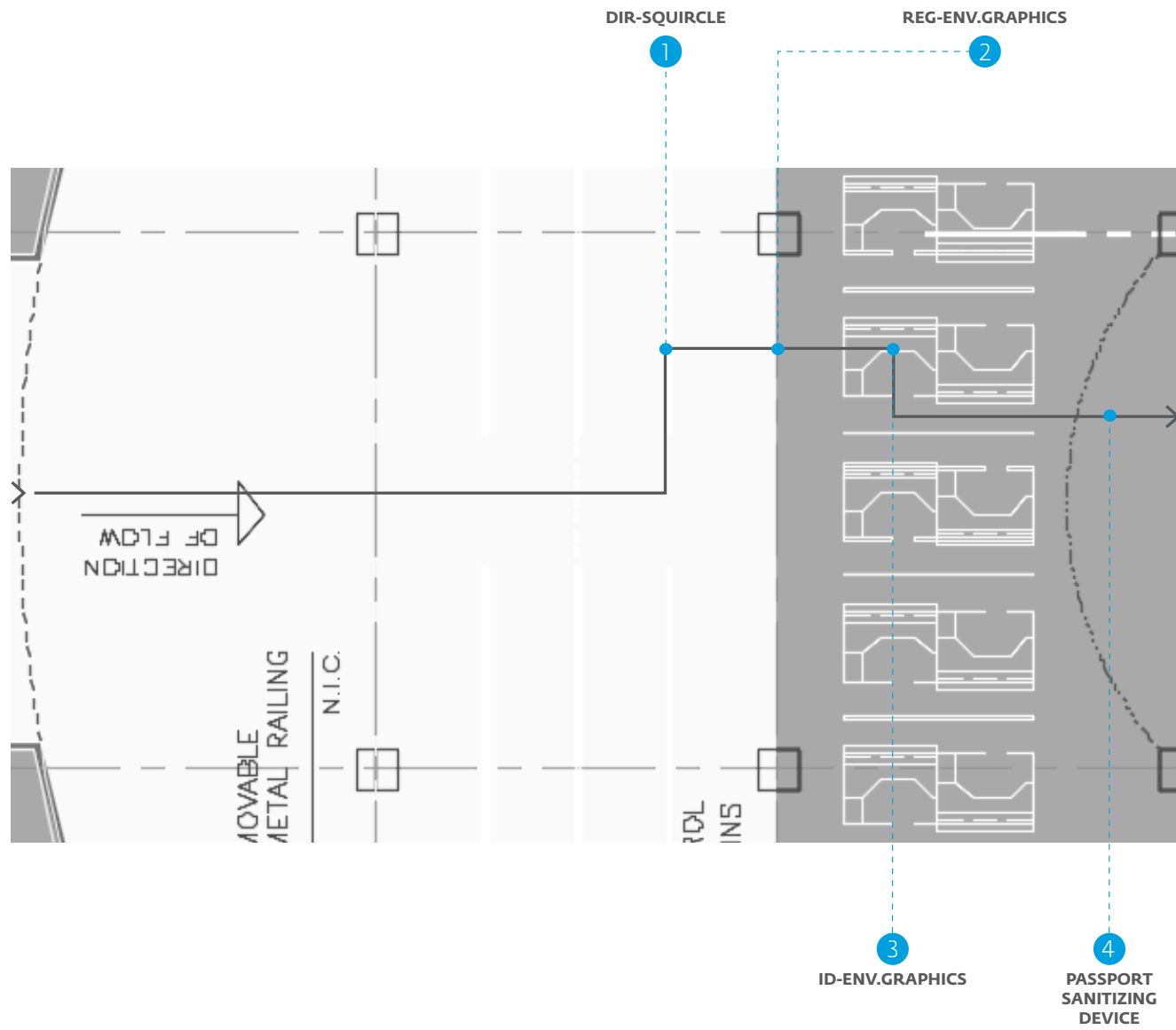

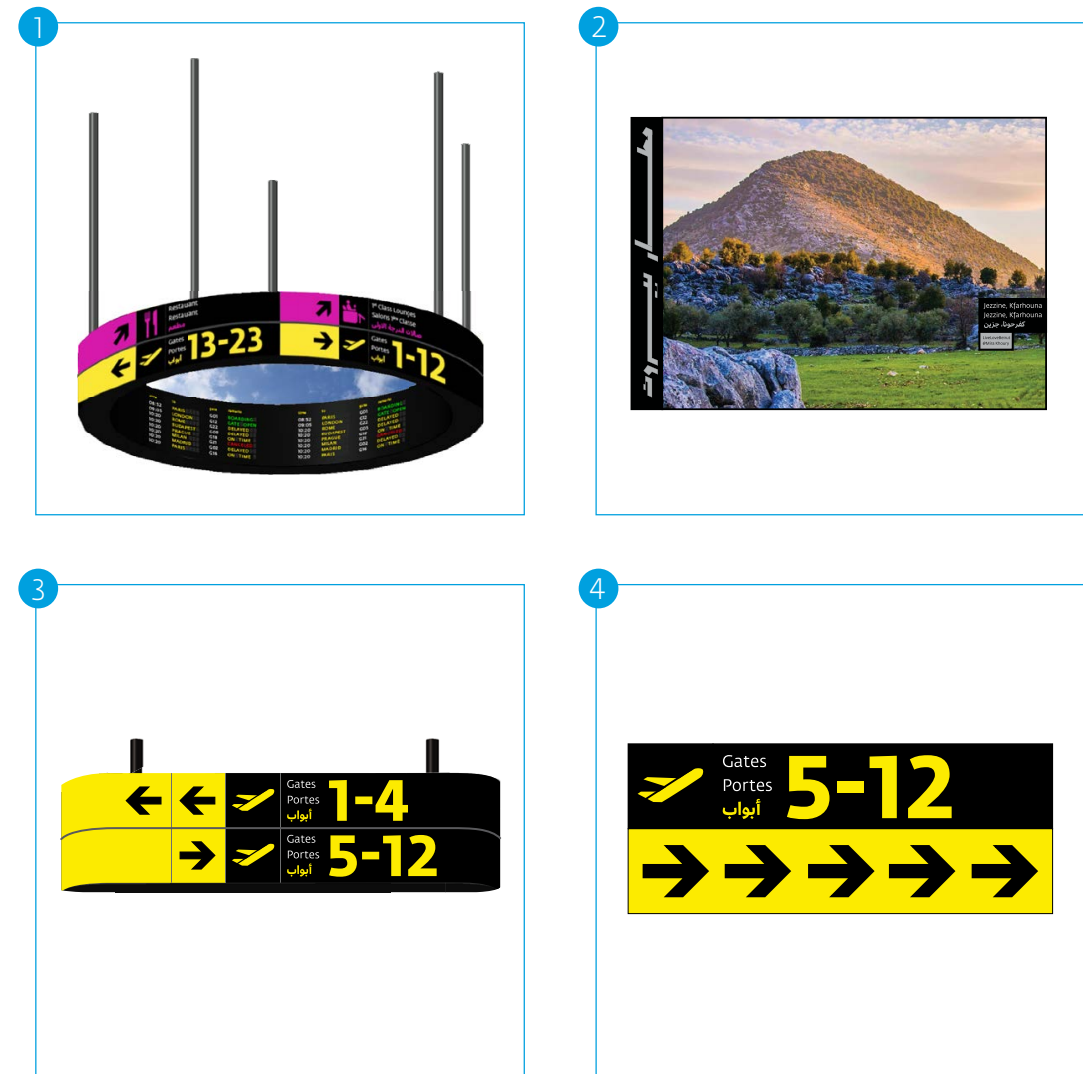
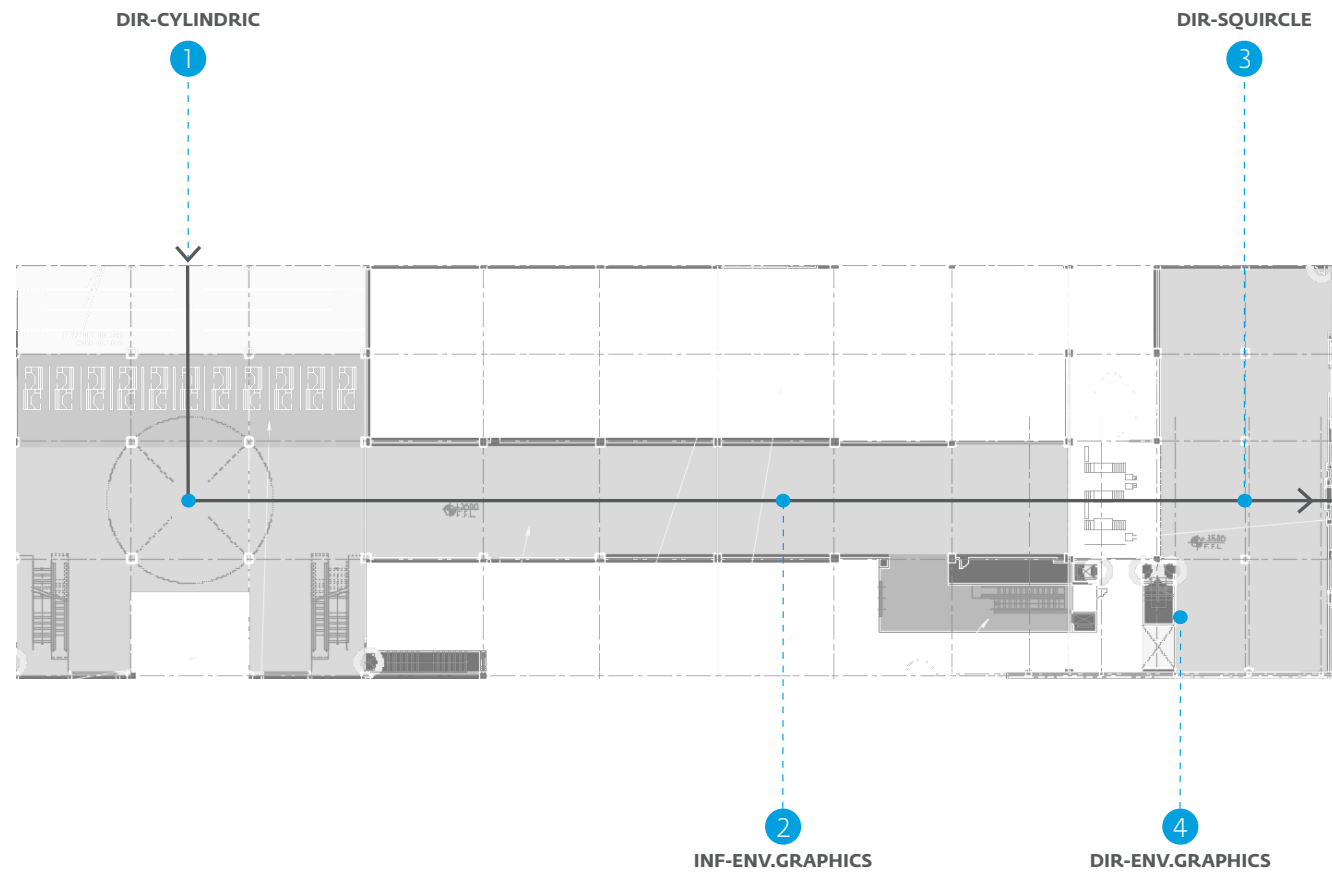

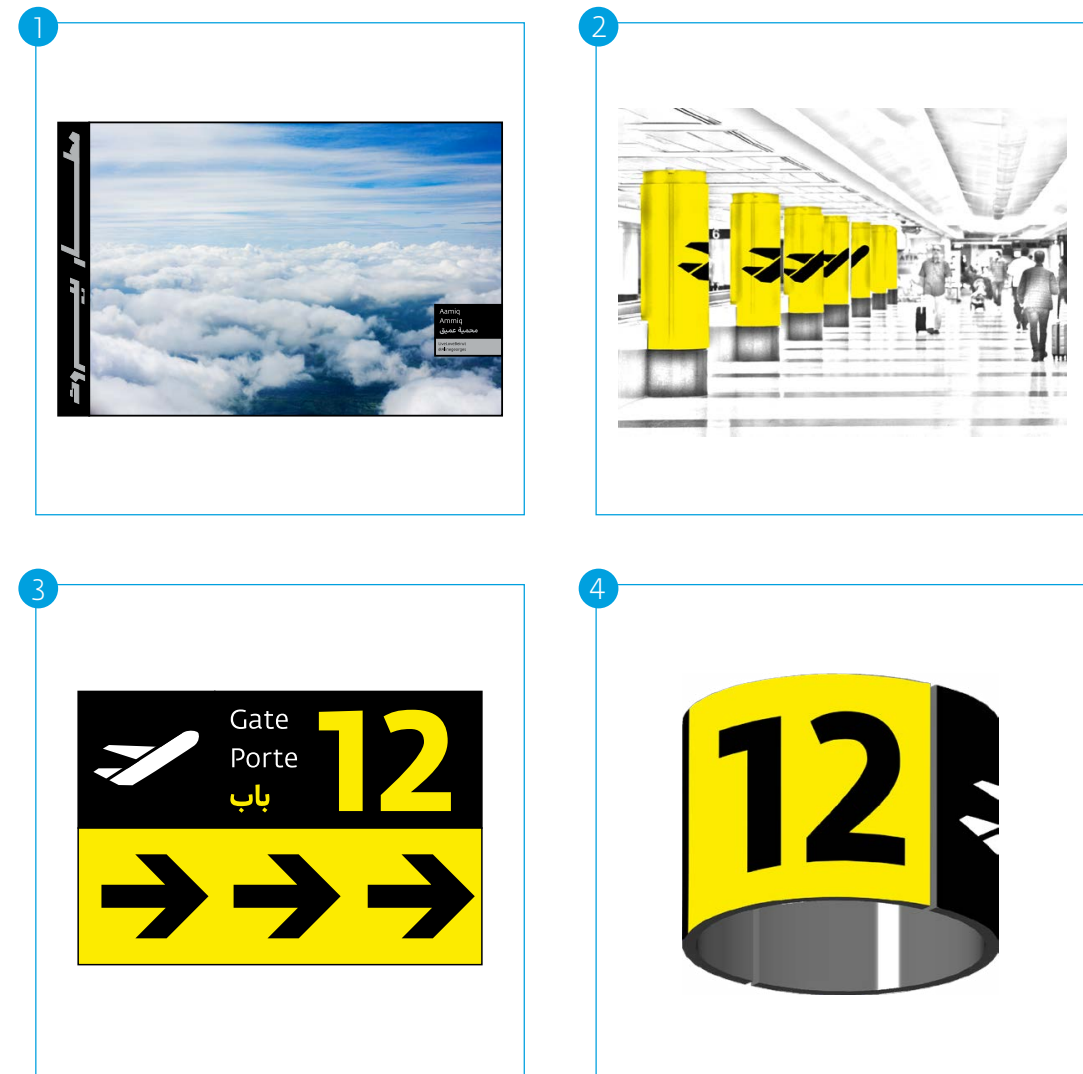
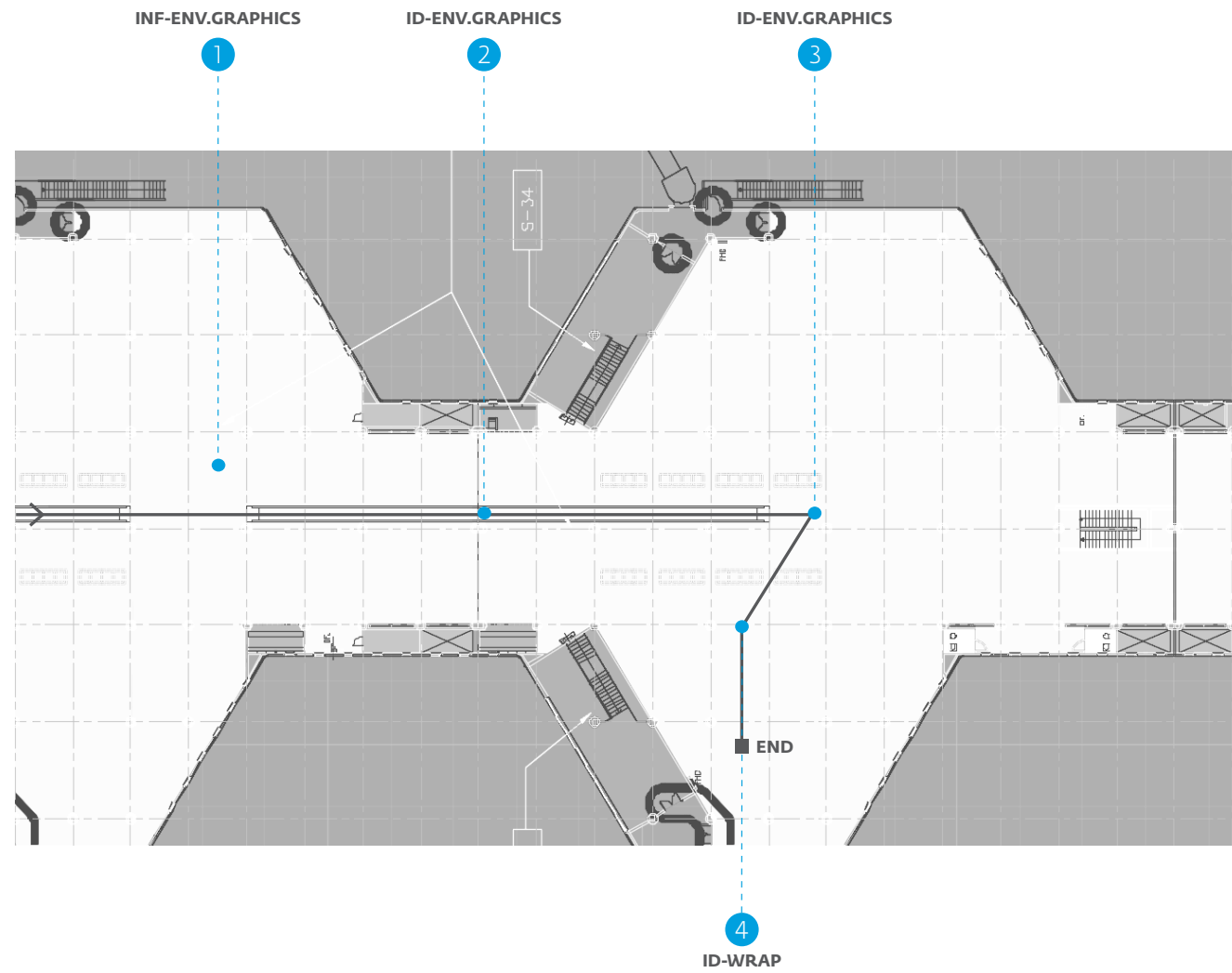

VII- ANNEX

Site visits

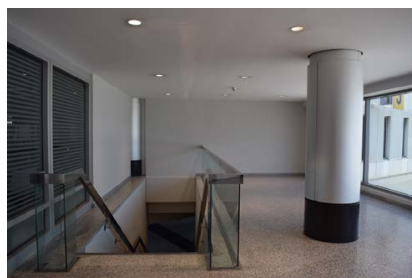
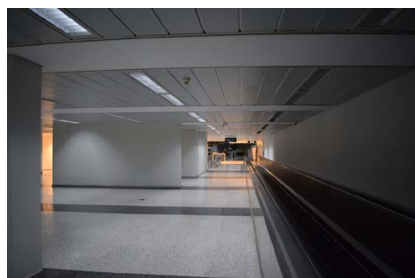
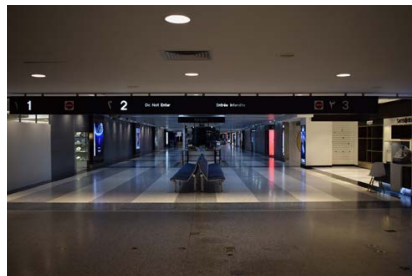
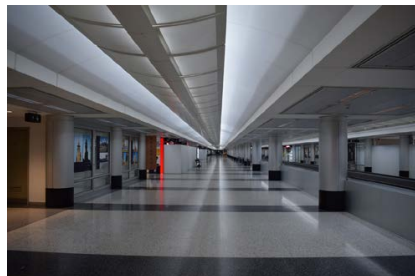
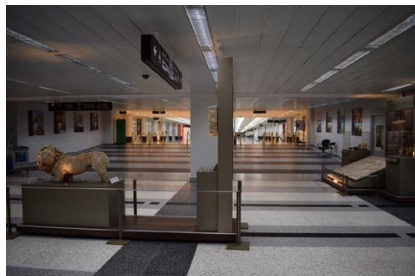
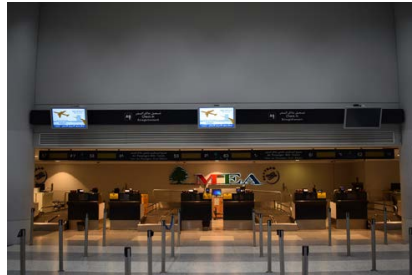
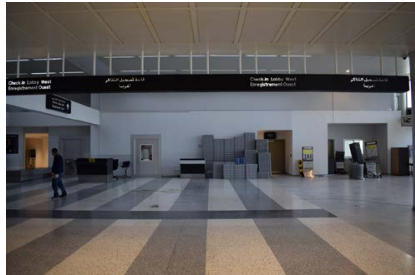

Site visits

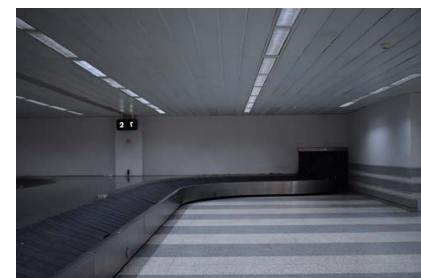
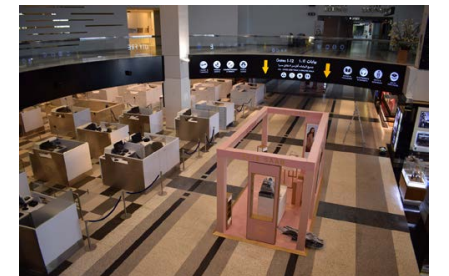
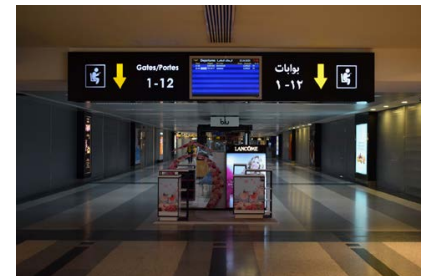
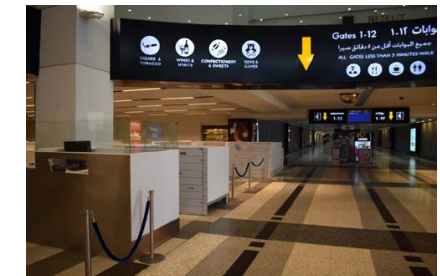
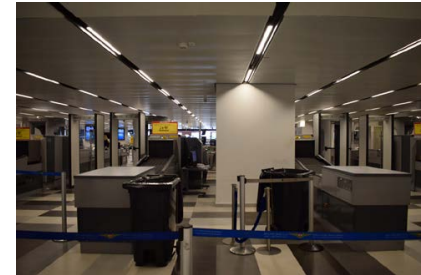
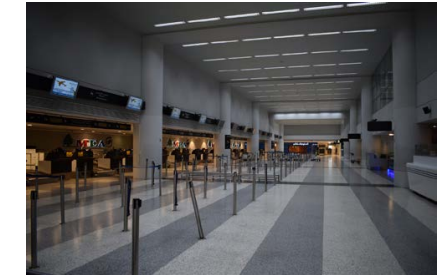
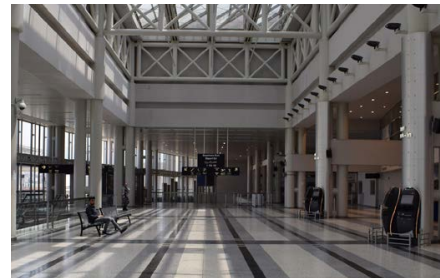

Site visits

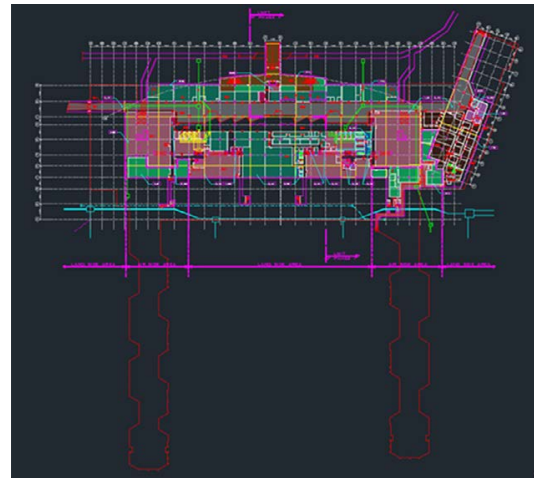
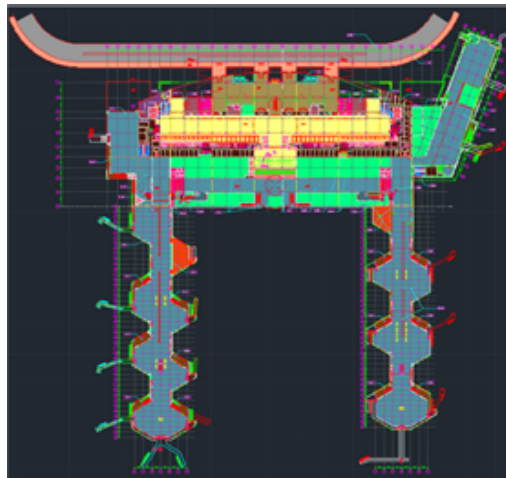
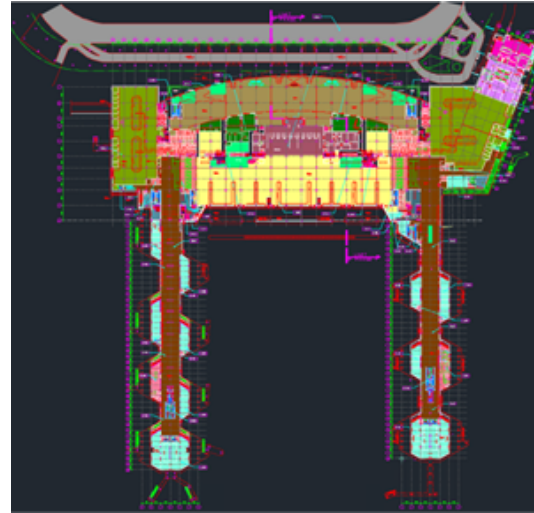
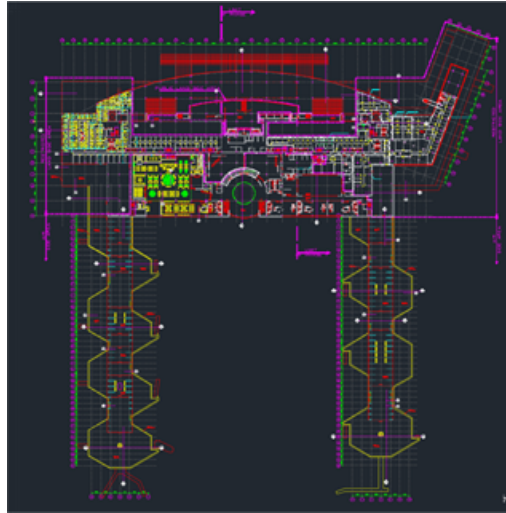

Acknowledgements

The completion of this project could not have been possible without the help, support and assistance of so many people whose name may not all be enumerated. Their contributions are sincerely appreciated and gratefully acknowledged. I would like to express my special appreciation and thanks particularly to the following:

My advisor, **Ms. Mia Azar** for imparting her knowledge and expertise in the project and for guiding me through.

The Beirut Rafic Hariri International Airport Security Authority and Presidency, for giving me the possibility to access the Airport and completing my project. And especially, **Colonel Ahmad Baytamouni** for giving me his huge help and support since the beginning in completing my project successfully.

Most importantly, I would like to thank my **family and friends** for supporting me morally and for their encouragement and motivation towards the completion of this project.

